

L L C " N T C " Z E R S "

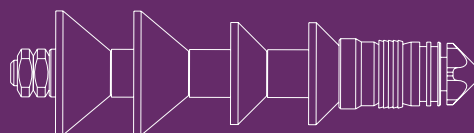

# COMPLETION EQUIPMENT

2019



# CATALOGUE 2019



## “WELL COMPLETION, OPERATION AND WORKOVER”

A vast experience in creation of new equipment and careful analysis of its function through field conditions allowed to invent and protect by patents a row of new generation devices. The responsibility for quality of products, terms of its production, possibility of carrying out independent price policy led to creation of own production that allowed “ZERS” to capture all stages of creation of products from development through production to introduction which interaction leads to achievement of more and more perfect results every year.



# ZERS is Company of a full cycle

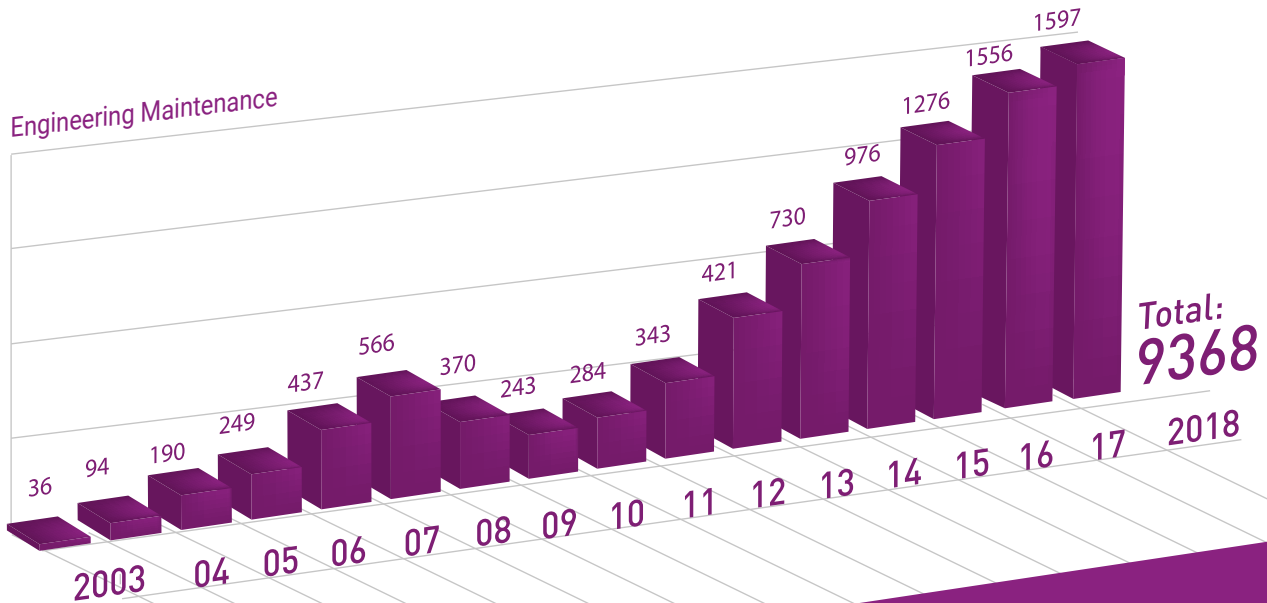

As for today  
there are

**more than  
250 000**

items  
of equipment  
are in wellbores

Ltd Company "Scientific and Technical center ZERS"  
in 2018 it was 20 years executed.

Our company develops, produces and delivers  
a huge list of technical equipment for Completion,  
Well Service, Workover and Production of oil and  
gas wells, and also engineering and technological  
maintenance in field usage of equipment.

Ltd Company "Scientific and Technical Center ZERS"  
owns two production sites, equipped with modern  
machine park with microprocessor based systems,  
testing and experimental base and also representation  
agencies on main oilfields of Russian Federation and  
cities as Buzuluk, Noyabrsk, Nizhnevartovsk and  
Irkutsk.

BUSINESS GEOGRAPHY



PLANT  
KAUNAS

**3320 m<sup>2</sup>** Total floor space

**94** Number of employees

**87%** Experts of the highest level



PLANT  
RYAZAN

**9768 m<sup>2</sup>** Total floor space

**205** Number of employees

**80%** Experts of the highest level

# CERTIFICATES & LICENSES



**ТАМОЖЕННЫЙ СОЮЗ**

**Еurasian Conformity Certificate**

**№ TC / RU C RU 0008 0 0004**  
Серия RU / M 0120013

**ОРГАНИЗАЦИЯ-ИЗДАТЕЛЬ** Организация с ограниченной ответственностью «ИЗДАТЕЛЬ «СЕРТИФИКАТ»» Адрес: 140204, Московская область, г. Люберцы, 1-я Рязанская улица, д. 17, стр. № 10 (подземный, 44074), Московская область, г. Люберцы, 1-я Рязанская улица, д. 17, офис 110 (Звонковский), Телефон: (495) 544800, 8002048, Факс: (495) 544911, E-mail: info@cert.ru, info@cert.ru@yandex.ru, сайт: www.cert.ru, www.cert.ru@yandex.ru

**ИЗДАТЕЛЬ** Общество с ограниченной ответственностью «ИЗДАТЕЛЬ «СЕРТИФИКАТ»» Адрес: Россия, 125147, г. Москва, Б. Филевский пер., д. 27, подъезд № 1 (подземный), Россия, 125148, Москва, ул. Новая Басманная, д. 14, стр. 1 (Звонковский), СТР № 10000180000, Телефон: (495) 632144, Факс: (495) 632147, E-mail: info@cert.ru

**ИЗДАТЕЛЬ** Общество с ограниченной ответственностью «ИЗДАТЕЛЬ «СЕРТИФИКАТ»» Адрес: Россия, 125147, г. Москва, Б. Филевский пер., д. 27, подъезд № 1 (подземный), Россия, 125148, Москва, ул. Новая Басманная, д. 14, стр. 1 (Звонковский), СТР № 10000180000, Телефон: (495) 632144, Факс: (495) 632147, E-mail: info@cert.ru

**ИЗДАТЕЛЬ** Оборудование и комплект для автоматизации и крупногабаритные станки (станки) с 2-х листов (Листы № 000604 и № 000605) Серийный выпуск

**КОД ОКР НА ТУ** 8431 43 000 0

**СООТВЕТСТВУЕТ ТРЕБОВАНИЯМ** Технические требования Таможенного союза ТР ТС 0102/2011 "О безопасности машин и оборудования" (Утвержден Решением Комиссии Таможенного союза от 18 ноября 2011 г. № 820)

**СЕРТИФИКАТ ВКЛЮЧАЕТ ОБОЗНАЧЕНИЕ** продукция сертифицирована в соответствии с 4074 от 03.11.2014 г. «О внесении изменений в постановление Правительства Российской Федерации от 05.03.2014 г. № 149 по результатам анализа результатов производства от 03.11.2014 г., проведенного в рамках по сертификации импортного оборудования ИИТ «ИЗДАТЕЛЬ «СЕРТИФИКАТ»» (Сертификат идентификации № RUCC RU 0007 114008 действительный от 03.06.2014 г.)

**ДОПОЛНИТЕЛЬНАЯ ИНФОРМАЦИЯ** Удостоверение - № ПССТ 10130 4292) Срок действия без ограничений - не более 10 лет/дней. Срок действия после даты окончания действия Удостоверения - неограниченно.

Срок действия: 03.12.2014 г. - 03.12.2019 г. - БЕЛОРУССКАЯ

 А.К. Зубов  
В.В. Селев

**ТАМОЖЕННЫЙ СОЮЗ**

**Еurasian Conformity Certificate**

**№ TC / RU C RU 0008 0 0299**  
Серия RU / M 0120013

**ОРГАНИЗАЦИЯ-ИЗДАТЕЛЬ** Организация с ограниченной ответственностью «ИЗДАТЕЛЬ «СЕРТИФИКАТ»» Адрес: 140204, Московская область, г. Люберцы, 1-я Рязанская улица, д. 17, стр. № 10 (подземный, 44074), Московская область, г. Люберцы, 1-я Рязанская улица, д. 17, офис 110 (Звонковский), Телефон: (495) 544800, 8002048, Факс: (495) 544911, E-mail: info@cert.ru, info@cert.ru@yandex.ru, сайт: www.cert.ru, www.cert.ru@yandex.ru

**ИЗДАТЕЛЬ** Общество с ограниченной ответственностью «ИЗДАТЕЛЬ «СЕРТИФИКАТ»» Адрес: Россия, 125147, г. Москва, Б. Филевский пер., д. 27, подъезд № 1 (подземный), Россия, 125148, Москва, ул. Новая Басманная, д. 14, стр. 1 (Звонковский), СТР № 10000180000, Телефон: (495) 632144, Факс: (495) 632147, E-mail: info@cert.ru

**ИЗДАТЕЛЬ** Общество с ограниченной ответственностью «ИЗДАТЕЛЬ «СЕРТИФИКАТ»» Адрес: Россия, 125147, г. Москва, Б. Филевский пер., д. 27, подъезд № 1 (подземный), Россия, 125148, Москва, ул. Новая Басманная, д. 14, стр. 1 (Звонковский), СТР № 10000180000, Телефон: (495) 632144, Факс: (495) 632147, E-mail: info@cert.ru

**ИЗДАТЕЛЬ** Оборудование и комплект для автоматизации и крупногабаритные станки (станки) с 2-х листов (Листы № 000604 и № 000605) Серийный выпуск

**КОД ОКР НА ТУ** 8431 43 000 0

**СООТВЕТСТВУЕТ ТРЕБОВАНИЯМ** Технические требования Таможенного союза ТР ТС 0102/2011 "О безопасности машин и оборудования" (Утвержден Решением Комиссии Таможенного союза от 18 ноября 2011 г. № 820)

**СЕРТИФИКАТ ВКЛЮЧАЕТ ОБОЗНАЧЕНИЕ** продукция сертифицирована в соответствии с 4074 от 03.11.2014 г. «О внесении изменений в постановление Правительства Российской Федерации от 05.03.2014 г. № 149 по результатам анализа результатов производства от 03.11.2014 г., проведенного в рамках по сертификации импортного оборудования ИИТ «ИЗДАТЕЛЬ «СЕРТИФИКАТ»» (Сертификат идентификации № RUCC RU 0007 114008 действительный от 03.06.2014 г.)

**ДОПОЛНИТЕЛЬНАЯ ИНФОРМАЦИЯ** Удостоверение - № ПССТ 10130 4292) Срок действия без ограничений - не более 10 лет/дней. Срок действия после даты окончания действия Удостоверения - неограниченно.

Срок действия: 03.12.2014 г. - 03.12.2019 г. - БЕЛОРУССКАЯ

 А.К. Зубов  
В.В. Селев





# CONTENTS

Certificates and Licenses .....	4
<b>I. LINER HANGERS</b>	
Noncemented Retrievable Liner Hanger PHN-E .....	10
Noncemented Liner Hanger PHN1 .....	12
Noncemented Liner Hanger PHN2 .....	16
Noncemented Liner Hanger rotating while running in PHNV .....	20
Noncemented Liner Hanger with oriented PHN-KO .....	22
Protected Cemented Liner Hanger PHCZ .....	24
Protected Rotated Cemented Liner Hanger PHCZV .....	27
Hydro-Mechanical Cemented Liner Hanger PHGMC .....	30
Protected Hydro-Mechanical Cemented Liner Hanger PHGMCZ .....	34
Liner Hanger with disconnection before cementing PHRC .....	36
Cemented Liner Hanger for flush-joint pipes PHCBT .....	40
Protected Liner Hanger for stage cementing PHZSC .....	42
Liner hanger assembly, revolving while cementing PHVC .....	44
Liner Hanger with two kinds of release before cementing PHGMRC .....	46
<b>II. PACKERS</b>	
Protected Hydraulic Packer PGRPZ .....	50
Hydraulic Full-Bore Packer PGP, PGP1, PGP6 .....	52
Cross-flow Sealing Packer PGMP .....	54
Hydraulic Full-Bore Packer with Small-Size Valve Unit PGPM1.245 .....	56
Hydraulic Packer for Collar Cementing PGMC, PGMC2, PGMC4, PGMC6 .....	58
Collar Cementing Packer PMC, PMC-R .....	62
Water-Swellable and Oil-Swellable Packer PNV and PNN .....	64
<b>III. EXTERNAL CASING ATTACHMENTS</b>	
Collar for Collar Cementing MMC1 .....	70
String Disconnect for Water Wells RKVS .....	72
Multiple-Unit Rotating Disconnect RKVO .....	74
Collar Cementing Valve KMC .....	76
Cementing Basket CK .....	77
Pressure Test Device PO .....	78
Stage-by-stage Casing Running Tool USSK, USSKP .....	80
Hydraulic Fracturing Sealing Assembly UGRH .....	82
Screener UECS .....	84
Ball Check Valve KOSH2, KOSHBT .....	86



Seat-Trap SL.....	90
Auxiliary Top Modular Packer PDV-M.....	91
Top Auxiliary Packer PDV2 .....	92
Trip Stop-Tap CPD2.....	94
Bow-Spring Centralizer PC .....	96
Hard Elastic Centralizer PCR .....	98
Low-frictional Turbulence Generating Centralizer CTN .....	99
Stop Ring SKC.....	100
Cementing Throttle Check Valve CKOD .....	101
Casing Shoe BK.....	102
Well Screen FS, FB.....	106

#### **IV. DRILLING EQUIPMENT**

Selective Washing Device for Wells USPS .....	114
---	-----

#### **V. HYDRAULIC FRACTURING**

Technical Equipment Set for a Liner Well Casing with the following Multistage Hydraulic Fracturing .....	118
Hydraulic Packer for Hydraulic Fracturing PGRP .....	120
Water and Oil Swellable Packer for Hydraulic Fracturing .....	122
Closing Frac Port FPZ and FPZN.....	124
Dissolvable balls .....	126
Bursting frac port FPR.....	127
Composite bridge plug MPR.....	128
Collar for Collar Cementing Sleeve for Hydraulic Fracturing MMC-G.....	130
Collar control tong KUM.114.....	132
Collar for Staged Hydraulic Fracturing with an Operating Device MSGRP-U.....	133

#### **VI. EXAMPLES OF ASSEMBLIES APPLIED FOR DIFFERENT PURPOSES**

Well Casing with Noncementing Liner.....	136
Well Casing with Noncementing Liner with Washing through a Shoe with Zonal Isolation by Swellable Packers.....	137
Well Casing with Noncementing Liner with Zonal Isolation by Inflatable Packers .....	138
Well Casing with Cementing Liner with Continuous Cementing with Zonal Isolation by Inflatable Packers .....	139
Well Casing with Collar Cementing Liner with Additional Isolation of Upper Zones by Inflatable Packers.....	140
Well Casing with Noncementing Liner with Packaging for MSHF and Zonal Isolation by Swellable Packers.....	141
Well Casing with Collar Cementing Liner with Packaging for MSHF and Zonal Isolation by Swellable Packers .....	142
Well Casing with Collar Cementing Liner with Packaging for MSHF and Zonal Isolation by Hydraulic Packers.....	143
Well Casing with Collar Cementing Liner with Two-Stage Cementing .....	144
Well Casing with Cementing Liner with Continuous Cementing Followed by Multistage Hydraulic Fracturing.....	145



# LINER HANGERS

Noncemented  
Retrievable  
Liner Hanger

**PHN-E**

**10**

Noncemented  
Liner Hanger

**PHN1**

**12**

Noncemented  
Liner Hanger

**PHN2**

**16**

Noncemented  
Liner Hanger rotating  
while running in

**PHNV**

**20**

Noncemented  
Liner Hanger  
with oriented wedge

**PHN-KO**

**22**

Protected  
Cemented  
Liner Hanger

**PHCZ**

**24**

Protected  
Rotated Cemented  
Liner Hanger

**PHCZV**

**27**

Hydro-Mechanical  
Cemented  
Liner Hanger

**PHGMC**

**30**

Protected  
Hydro-Mechanical  
Cemented Liner Hanger

**PHGMCZ**

**34**

Liner Hanger  
with disconnection  
before cementing

**PHRC**

**36**

Cemented  
Liner Hanger  
for flush-joint pipes

**PHCBT**

**40**

Protected  
Liner Hanger  
for stage cementing

**PHZSC**

**42**

Liner hanger  
assembly,  
revolving while cementing

**PHVC**

**44**

Liner Hanger  
with two kinds  
of release before cementing

**PHGMRC**

**46**



## Noncemented retrievable liner hanger

### PHN-E

The PHN-E liner hanger is used to RIH and hang a small ID non-cemented liner, providing the possibility to retrieve the liner if required.

This PHN-E liner hanger consists of 2 parts::

- anchor to hang the liner assembly in the casing string;
- hydraulic disconnection that allows to RIH liner assembly, circulate, activate anchor by hydraulic pressure and, then, disconnect the drill string from PHN-E by applying hydraulic pressure.

To retrieve the liner assembly, the spear (special tool) is run and set inside the PHN-E. The overpool of 5 ton is then applied to release an anchor and start pulling the liner out.

PARAMETER DESCRIPTION	VALUE	
	PHN. 60/102-E	PHN. 73/114-E
Liner nominal OD, mm	60	73
Casing nominal OD, mm	102	114
Maximum tool OD (at centralizer), mm	83	94
Drift ID (after activation), mm	50	60
Values of differential activation pressures <sup>1</sup> , MPa		
- an anchor	11±10%	11±5%
- hydraulic disconnection device	16±10%	15±5%
Maximum axial load at disconnection (w/o liner assembly weight) <sup>1</sup> , kN (ton)	40 (4)	50 (5)
Maximum internal overpressure, MPa	20	20
Maximum operating temperature <sup>2</sup> , °C	100	
Maximum tensile force <sup>3</sup> , kN (ton)	200 (20)	300 (30)
Connecting threads:		
- top as per GOST 633-80	60	73
- bottom as per GOST 633-80	60	73
Length in operating position, mm	1308	1320
Weight in operating position, kg	30	32

<sup>1</sup> The values are given for all shear bolts installed.

<sup>2</sup> For reference only! – depends on operating conditions for rubber parts in a well.

<sup>3</sup> Calculated value when stresses reach tensile yield of the material.



## Noncemented liner hanger

### PHN1

The PHN1 liner hanger is used to RIH and hang non-cemented liners. It is manufactured in 2 modifications, differed by the type of internal space shut-off:

- by throttling valve, which gets closed by increased circulation rate;
- by pumping of cementing plug or activation ball, that land into a landing seat located at the bottom of hanger mandrel.
- PHN1 is equipped with UIF (unit of isolation of filters), allowing to circulate through the liner shoe.

PHN1 hanger consists of 4 functionally independent parts:

- anchor to hang the liner assembly in the casing string;
- hydro-mechanical packer to isolate annular space;
- hydraulic release mechanism that allows to RIH liner assembly, circulate, activate anchor/packer by hydraulic pressure and, then, disconnect the drill string from PHN1 by applying hydraulic pressure.
- mechanical release to back up a hydraulic disconnection mechanism.

Design of PHN1 is practically identical to that of PHCZ1, except that at the end of tool mandrel, there installed a landing seat or a throttling shut-off valve, instead of hollow cement plug, and mandrel has circulation ports.

PARAMETER DESCRIPTION	VALUE		
	PHN1.102/146; PHN1.102/146-01	PHN1.114/168; PHN1.114/168-01	PHN1.114/168-UIF
Liner nominal OD, mm	102	114	
Casing nominal OD, mm	146	168	
Maximum anchoring casing ID, mm	135	154	
Maximum tool OD (at centralizer), mm	120 (122)	138 (141)	
Drift ID (after activation), mm	89	99	
Values of differential activation pressures <sup>1</sup> , MPa			
- anchor	16,5	16	
- packer	16,5	16	
- hydraulic disconnection device	20	20	
Maximum differential pressure on packer, MPa		15	
Maximum operating temperature <sup>2</sup> , °C		100	
Maximum axial tensile load on disconnection device <sup>3</sup> , kN	600	700	
Connecting threads <sup>4</sup> :			
- top GOST 28487 (GOST R 50864)	Z-86	Z-102	Z-102
- bottom GOST 632-80	OTTM 102	OTTM 114	OTTM 114
- pup-joint GOST 633	-	-	60
Length in operating position, mm	3340	3331	3563
Weight in operating position, kg	119 (125)	160 (163)	170

<sup>1</sup> The values are given for all shear bolts installed.

<sup>2</sup> For reference only! – depends on operating conditions for rubber parts in a well.

<sup>3</sup> Calculated value when stresses reach tensile yield of the material.

PARAMETER DESCRIPTION	VALUE			
	PHN1.127/178; PHN1.127/178-01	PHN1.127/178-114; PHN1.127/178-114-01	PHN1.127/178-UJIF	PHN1.127/178-114-UJIF
Liner nominal OD, mm	127	114	127	114
Casing nominal OD, mm	178	178	178	178
Maximum anchoring casing ID, mm	166			
Maximum tool OD (at centralizer), mm	149 (152)			
Drift ID (after activation), mm	111	99	111	99
Values of differential activation pressures <sup>1</sup> , MPa				
- anchor	16			
- packer	16			
- hydraulic disconnection device	20			
Maximum differential pressure on packer, MPa	15			
Maximum operating temperature <sup>2</sup> , °C	100			
Maximum axial tensile load on disconnection device <sup>3</sup> , kN	800	700	800	700
Connecting threads <sup>4</sup> :				
- top GOST 28487 (GOST R 50864)	3-102	3-102	3-102	3-102
- bottom GOST 632-80	OTTM 127	OTTM 114	OTTM 127	OTTM 114
- pup-joint GOST 633	–	–	60	60
Length in operating position, mm	3395	3375	3678	3678
Weight in operating position, kg	182 (185)	182 (185)	190	182

<sup>1</sup> The values are given for all shear bolts installed.

<sup>2</sup> For reference only! – depends on operating conditions for rubber parts in a well.

<sup>3</sup> Calculated value when stresses reach tensile yield of the material.







## Noncemented liner hanger

### PHN2

The PHN2 liner hanger is used to RIH and hang non-cemented liners.

PHN2 liner hanger consists of 4 functionally independent parts:

- anchor to hang the liner assembly in the casing string;
- mechanical packer to isolate annular space;
- hydraulic release mechanism that allows to RIH liner assembly, circulate, activate anchor by hydraulic pressure, activate packer mechanically and, then, disconnect the drill string from PHN2 by applying hydraulic pressure.
- mechanical release to back up a hydraulic disconnection mechanism.

Design of PHN2 is practically identical to that of hydro-mechanical cemented liner hanger – PHGMC, except a landing seat installed at the bottom part of the mandrel.

Liner hangers PHN2.114/168, PHN2.127/178 and PHN2.127/178-114 are produced in UIF (unit of isolation of filters) configuration, which allows to perform circulation through the shoe.

PARAMETER DESCRIPTION	VALUE		
	PHN2.102/140	PHN2.102/146	PHN2.114/168
Liner nominal OD, mm	102	102	114
Casing nominal OD, mm	140	146	168
Maximum anchoring casing ID, mm	127	132	132
Maximum tool OD (at centralizer), mm	115 (117)	120 (122)	138 (141)
Drift ID (after activation), mm	85	89	99
Values of differential activation pressures <sup>1</sup> , MPa			
- anchor		14	
- hydraulic disconnection device		20	
Load on packer for activation, kN		150	
Maximum differential pressure between the zones isolated by a packer unit, MPa		30	
Maximum operating temperature <sup>2</sup> , °C		100	
Maximum axial tensile load on disconnection <sup>3</sup> , kN	600	600	700
Connecting threads <sup>4</sup> :			
- top GOST 28487 (GOST R 50864)	Z-86	Z-102	Z-102
- bottom GOST 632-80	OTTM 102	OTTM 102	OTTM 114
Length in operating position, mm	3612	3834	3810
Weight in operating position, kg	108	135	152

<sup>1</sup> The values are given for all shear bolts installed.

<sup>2</sup> For reference only! – depends on operating conditions for rubber parts in a well.

<sup>3</sup> Calculated value when stresses reach tensile yield of the material.

<sup>4</sup> In PHN2.102/140 and PHN2.102/146 thread OTTM-102 is produced according to TU 14-161-163.

PARAMETER DESCRIPTION	VALUE			
	PHN2. 127/178	PHN2. 127/178-114	PHN2. 168/245	PHN2. 178/245
Liner nominal OD, mm	127	114	168	178
Casing nominal OD, mm	178	178	245	245
Maximum anchoring casing ID, mm	160	167	231	231
Maximum tool OD (at centralizer), mm	150 (152)	149 (152)	211 (213)	211 (213)
Drift ID (after activation), mm	111	99	150,5	157
Values of differential activation pressures <sup>1</sup> , MPa				
- anchor			14	
- hydraulic disconnection device			20	
Load on packer for activation, kN			150	
Maximum differential pressure between the zones isolated by a packer unit, MPa			30	
Maximum operating temperature <sup>2</sup> , °C			100	
Maximum axial tensile load on disconnection <sup>3</sup> , kN	800	700	1000	1000
Connecting threads <sup>4</sup> :				
- top GOST 28487 (GOST R 50864)	Z-102	Z-102	Z-133	Z-133
- bottom GOST 632-80	OTTM 127	OTTM 114	OTTM 168	OTTM 178
Length in operating position, mm	4138	4183	3769	4095
Weight in operating position, kg	209	240	385	420

<sup>1</sup> The values are given for all shear bolts installed.

<sup>2</sup> For reference only! – depends on operating conditions for rubber parts in a well.

<sup>3</sup> Calculated value when stresses reach tensile yield of the material.

<sup>4</sup> In PHN2.102/140 and PHN2.102/146 thread OTTM-102 is produced according to TU 14-161-163.



**DMC**

Unit: Feedrate enable missing

102.004  
25.667

T.F.S

T R01B

3 D1

F

0.000

0.000

mm/rev

S4

0

Master

0

50

Basic blocks

100

100%

150

Time / counter

Program levels

Act. values  
Machine

Simult. record.

Program



## Rotating non-cemented liner hanger PHNV

The PHNV liner hanger is used to RIH and hang non-cemented liners, providing the capability to rotate an assembly while running.

PHNV liner hangers, can be produced in UIF (unit of isolation of filters) configuration, allowing to perform circulation through the liner shoe.

PHNV liner hanger consists of four functionally independent components:

- anchor to hang the liner assembly in the casing string;
- hydro-mechanical packer to isolate annular space;
- hydraulic release mechanism that allows to RIH liner assembly, circulate, activate anchor/packer by hydraulic pressure and, then, disconnect the drill string from PHN1 by applying hydraulic pressure.
- mechanical disconnection to back up a hydraulic release mechanism.

PARAMETER DESCRIPTION	VALUE
	PHNV1.127/178-114-UIF OTTG
Liner nominal OD, mm	114
Casing nominal OD, mm	178
Maximum torque, kN*m	8
Maximum tool OD (at centralizer), mm	149 (152)
Drift ID (after activation), mm	99
Values of differential activation pressures <sup>1</sup> , MPa	
- anchor	16
- packer	16
- hydraulic disconnection device	20
Maximum differential pressure on packer, MPa	15
Maximum operating temperature <sup>2</sup> , °C	100
Maximum axial tensile load on disconnection <sup>3</sup> , kN	700 (70)
Connecting threads <sup>4</sup> :	
- top GOST 28487 (GOST R 50864)	Z-102
- bottom GOST 632-80	ОТТГ114
- pup-joint GOST 633	60
Length in operating position, mm	3950
Weight in operating position, kg	192

<sup>1</sup> The values are given for all shear bolts installed.

<sup>2</sup> For reference only! – depends on operating conditions for rubber parts in a well.

<sup>3</sup> Calculated value when stresses reach tensile yield of the material.



## Noncemented liner hanger with oriented whipstock **PHN-KO**

The PHN-KO liner hanger with oriented whipstock is used to RIH and hang non-cemented liners before kicking-off a second wellbore and running another non-cemented liner in it. The Strings with Bottom Hole Assemblies are issued in two executions PHN-KO2 and PHN-KO5 with a way of disconnection :

- PHN-KO2 Break up with pulling up tension after anchor actuation;
- PHNH-KO5 Hydraulic break up with increase of pressure;

Disconnection of Drilling String while pulling 25 tons over (PHN-KO2), or increasing pressure to 20 MPa (PHN – K05)

When using PHN-KO, the following operations are performed:

- the PHN-KO is RIH as a part of the liner assembly on drill string;
- azimuthal orientation of the whipstock in the well by the orienting tool – UOKS;
- hydraulic anchor actuation by increasing the pressure up to 16 MPa;

The working mechanism of the hanger provides whipstock orientation in required direction. The pressure on the hanger parts is only transmitted if the whipstock is correctly set.



PARAMETER DESCRIPTION	VALUE		
	PHN-K02.153	PHN-K02.143	PHN-K05.153A
Nominal diameter of casing, equipped with tools, mm	114	114	114
Max Outside diameter, mm	145	136	145
Drift diameter after actuation, mm	60	60	58
Length of tool in working position, mm	6639	5610	7535
Weight of tool in working position, kg	433	423	473
Drill bit diameter for re-entry hole drilling, mm	152,4	142,9	152,4
Values of internal overpressures actuating devices, MPA			
- Anchor unit	14–16	14–16	13
- Disconnecter unit	–	–	16
Axial load after activating anchor and provides disengagement of trigger tool, kN	200	200	-
Whipstock kick-off angle	2°30'	2°30'	2°30'
Maximum operating temperature <sup>2</sup> , °C	100	100	100
Maximum tensile axial force <sup>3</sup> , kN	400	400	600
Connecting threads:			
- Top thread - Gov't Standard 28487 (R 50864)	3-86	3-86	3-86
- Bottom thread – Gov't Standard 632	OTTM-114	OTTM-114	OTTM-114

<sup>1</sup> Pressure values are attached as per all shear pins of the unit are applied.

<sup>2</sup> Parameter reference while operations downhole conditions.

<sup>3</sup> Estimated value, at which stresses reach the yield strength of the material .



## Protected cemented liner hanger PHCZ

The PHCZ liner hanger is used to RIH and hang cemented liners and allows to sequentially perform well cementing operations, set hydraulic anchor, packer and, then, disconnect a drill string.

PHCZ liner hanger can be used in vertical, deviated, sub horizontal and horizontal wells, where it is required to run and cement a liner.

PHCZ liner hanger consists of four functionally independent components:

- anchor to hang the liner assembly in the casing string;
- hydro-mechanical packer to isolate annular space;
- hydraulic release mechanism that allows to RIH liner assembly, circulate, activate anchor/packer by hydraulic pressure and, then, disconnect the drill string from PHCZ by applying hydraulic pressure;
- mechanical release to back up a hydraulic disconnection.

After the liner is run to the bottom and required circulations (washovers) are carried out, PHCZ activation is carried out as follows:

- cement is pumped into a well and cement plug is lunched to separate it from displacement fluid;
- cement slurry is displaced into the liner-open hole annular space until the plug "bumps";
- while well head pressure "on bump" increases, the hydraulic anchor gets set when pressure differential reaches 16 MPa. The pressure is passed through a hollow pin to the inner space of anchor's fluid drive, which moves slips radially to latch on casing walls;
- hydraulic packer is activated simultaneously with anchor by differential pressure of 16 MPa. The pressure activates packer's fluid drive, which creates force to a plunger sleeve to cut the shear pins and start moving while squeezing rubber seals split by centralizer: the seals deform and press against casing walls;
- when pressure differential reaches 20 MPa, the hydraulic disconnection device gets activated. The pressure on plunger creates force required to cut shear pins and move to release arresters, thus disconnecting the drill string from hanger;
- in case of problems with hydraulic release mechanism, the mechanical disconnection is activated by, first, adjusting weight indicator reading to the weight of the drill string in fluid and, second, rotating the drill string by 20 turns clockwise (to the right);
- circulation/washover is performed and drill pipe is POOH.

Depending on cementing job type required, the hanger/liner system is equipped with:

*for the "bottom up" liner cementing:*

The first liner pipe is equipped with a plug catcher, check valve and casing shoe. PHCZ is connected to the last liner pipe.

*for liner top cementing*

The first liner pipe is equipped with a shoe, the last liner pipe (in productive zone) is equipped with packer, such as PGMC, PGMC2 or PGMC4. PHCZ is connected to the last liner pipe.

PARAMETER DESCRIPTION	VALUE		
	PHCZ.89/140-76	PHCZ1.102/146	PHCZ1.114/168
Liner nominal OD, mm	89	102	114
Casing OD, recommended wall thickness, (ID) of casing to use PHCZ, mm	139,7*9,2 (121,3)	146,1*7,7 (130,7)	168,3*8,9 (150,5)
Maximum OD (at centralizer), mm	111 (114)	120 (122)	138 (141)
Drift ID after activation, mm	76	89	99
Maximum casing ID, where anchoring can be performed, mm	128	137	155
Values of differential activation pressures <sup>1</sup> , MPa			
- anchor		16	
- packer		16	
- hydraulic disconnection device		20	
Maximum pressure differential on packer, MPa		15	
Maximum operating temperature <sup>2</sup> , °C		100	
Maximum axial tensile load on hanger body parts <sup>3</sup> , kN	600	600	700
Connecting threads <sup>4</sup> :			
- top GOST 28487 (GOST R 50864)	Z-86	Z-86	Z-102
- bottom GOST 632-80	89	OTTM 102	OTTM 114
Length in operating position, mm	3361	3788	3757
Weight in operating position, kg	107	140	174,4

<sup>1</sup> The values are given for all shear pins installed.

<sup>2</sup> For reference only! – depends on operating conditions for rubber parts in a well.

<sup>3</sup> Calculated value when stresses reach tensile yield of the material.

<sup>4</sup> For PHCZ.89/140-76 bottom thread is made accordingly to GOST 633. For PHCZ.102/140-80/117, PHCZ1.102/146, PHCZ1.114/168-102, PHCZ1.127/178-102 thread OTTM-102 is made accordingly to TR 14-161-163.

PARAMETER DESCRIPTION	VALUE			
	PHCZ1. 114/168-102	PHCZ1. 127/178	PHCZ1. 127/178-114	PHCZ1. 127/178-102
Liner nominal OD, mm	102	127	114	102
Casing OD, recommended wall thickness, (ID) of casing to use PHCZ, mm	168,3*8,9 (150,5)		177,8*10,4 (157)	
Maximum OD (at centralizer), mm	138 (141)		149 (152)	
Drift ID after activation, mm	89	111	99	89
Maximum casing ID, where anchoring can be performed, mm	155		167	
Values of differential activation pressures <sup>1</sup> , MPa				
- anchor			16	
- packer			16	
- hydraulic disconnection device			20	
Maximum differential pressure on packer, MPa			15	
Maximum operating temperature <sup>2</sup> , °C			100	
Maximum axial tensile load on hanger body parts <sup>3</sup> , kN	600	800	700	600
Connecting threads <sup>4</sup> :				
- top GOST 28487 (GOST R 50864)	Z-102	Z-102	Z-102	Z-102
- bottom GOST 632-80	OTTM 102	OTTM 127	OTTM 114	OTTM 102
Length in operating position, mm	3757	3678	3775	3765
Weight in operating position, kg	174,4	187	187	180,4

<sup>1</sup> The values are given for all shear pins installed.

<sup>2</sup> For reference only! – depends on operating conditions for rubber parts in a well.

<sup>3</sup> Calculated value when stresses reach tensile yield of the material.

<sup>4</sup> For PHCZ.89/140-76 bottom thread is in line with GOST 633. For PHCZ.102/140-80/117, PHCZ1.102/146, PHCZ1.114/168-102, PHCZ1.127/178-102 thread OTTM-102 is in line with to TR 14-161-163.



## Rotating protected cemented liner hanger PHCZV

PHCZV liner hanger is used to RIH and hang cemented liners, providing the capabilities to rotate an assembly while running, hang cemented liners and allows to sequentially perform well cementing operations, set hydraulic anchor, packer and, then, disconnect a drill string.

PHCZV liner hanger consists of four functionally independent components:

- anchor to hang the liner assembly in the casing string;
- hydro-mechanical packer to isolate annular space;
- hydraulic release mechanism that allows to RIH liner assembly, circulate, activate anchor/packer by hydraulic pressure and, then, disconnect the drill string from PHCZV by applying hydraulic pressure.
- mechanical disconnection that allows clockwise (to the right) assembly rotation while RIH and, at the same time, serves a backup to hydraulic disconnection. To disconnect the drill string, first, the half a turn counterclockwise turn is performed (to the left) to activate and, second, not less than 10 clockwise (to the right) turns to disconnect.

After the liner is run to the bottom and required circulations (washovers) are carried out, PHCZV activation is carried out as follows:

- cement is pumped into a well and cement plug is lunched to separate it from displacement fluid;
- cement slurry is displaced into the liner-open hole annular space until the plug "bumps";
- while well head pressure "on bump" increases, the hydraulic anchor gets set when pressure differential reaches 16 MPa;
- hydraulic packer is activated simultaneously with anchor by differential pressure of 16 MPa;
- when pressure differential reaches 20 MPa, the hydraulic disconnection gets activated;
- mechanical disconnection is activated by, first rotating the drill string by 1/2 turn counterclockwise (to the left) and, second, disconnected by not less than 10 turns clockwise (to the right);
- circulation/washover is performed and drill pipe is POOH.
- washover and pulling out of the transport string.

While well casing a liner includes the following technical units:

### *for liner continuous cementing*

liner casing starter is equipped with a shoe, than check-valve and stopping branch pipe. Hanger PHCZV is mounted on the last pipe of the liner which is connected with the transport string;

### *for liner collar cementing*

casing starter of liner filtering part is equipped with a shoe, above the filtering part a packer for collar cementing is mounted, PGMC, PGMC2 or PGMC4. Hanger PHCZV is mounted on the last part of the liner which is connected with the transport string.

PARAMETER DESCRIPTION	VALUE		
	PHCZV. 102/146	PHCZV. 114/168-102	PHCZV. 114/168
Liner nominal diameter RIH with the device, mm	102	102	114
Diameter, recommended wall thickness (ID) of casing string which the device is run into and installed, mm	146,*7,7 (130,7)	168,3*8,9 (150,5)	
Maximum OD of the device body (at centralizer), mm	120 (122)	138 (141)	138 (141)
Min. drift diameter after actuation, mm	89	89	99
Maximum torque, kN*m	6	7	7
Maximum ID of a casing string in which anchoring is performed, mm	137	155	155
Values of controlling internal overpressure for actuation of units <sup>1</sup> , MPa			
- anchor unit		16	
- packer unit		16	
- hydraulic disconnection device		20	
Maximum differential pressure between the zones isolated by a packer, MPa		15	
Maximum operating temperature <sup>2</sup> , °C		100	
Maximum tensile force on the body parts <sup>3</sup> kN	600	600	700
Connecting threads:			
- top GOST 28487 (GOST R 50864)	Z-86	Z 3-102	Z-102
- bottom GOST 632-80	TMK PF 102	TMK PF 102	OTTG 114
Length in operating position, mm	3894	4023	4023
Weight in operating position, kg	157	182	184

<sup>1</sup> Controlling overpressure values are given when all the shear bolts on the unit are used.

<sup>2</sup> Reference only, depends on operating conditions of general mechanical rubber goods in a well.

<sup>3</sup> Calculated value when stresses reach yield point of the material.

PARAMETER DESCRIPTION	VALUE	
	PHCZV. 127/178	PHCZV. 127/178-114
Liner nominal diameter RIH with the device, mm	127	114
Diameter, recommended wall thickness (ID) of casing string which the device is run into and installed, mm	177,8 *10,4 (157)	
Maximum OD of the device body (at centralizer), mm	149 (152)	149 (152)
Min. drift diameter after actuation, mm	111	99
Maximum torque, kN*m	8	8
Maximum ID of a casing string in which anchoring is performed, mm	167	167
Values of controlling internal overpressure for actuation of units <sup>1</sup> , MPa		
- anchor unit	16	
- packer unit	16	
- hydraulic disconnection	20	
Maximum differential pressure between the zones isolated by a packer, MPa	15	
Maximum operating temperature <sup>2</sup> , °C	100	
Maximum tensile force on the body parts <sup>3</sup> , kN	800	700
Connecting threads:		
- top GOST 28487 (GOST R 50864)	Z-102	Z-102
- bottom GOST 632-80	OTTG-127	OTTG-114
Length in operating position, mm	3945	3945
Weight in operating position, kg	195	201

<sup>1</sup> Controlling overpressure values are given when all the shear bolts on the unit are used.

<sup>2</sup> Reference only, depends on operating conditions of general mechanical rubber goods in a well.

<sup>3</sup> Calculated value when stresses reach yield point of the material.



## Hydro-mechanical cemented liner hanger **PHGMC**

Hydro-Mechanical Cemented Liner Hanger PHGMC is designed for RIH, hanging and sealing in of cementing liner, performing of technological operations connected with cementing and sequential actuation of an anchor unit and a packer unit and further automatic disconnection of transport string from the liner and transport string pulling out.

PHGMC hanger is a complex of four stand-alone and independent units:

- hydraulic anchor;
- hydraulic disconnection device;
- mechanical packer;
- mechanical release unit doubling the hydraulic one.

The hanger is provided with a number of interlocks: hydraulic breaking is protected against early actuation before the hollow suspended plug is cut, the packer may be actuated only after disconnection.

The hanger consists of two parts: adjustment tool and the hanger itself, the latter includes packer unit, anchor unit and lead-in funnel.

When using hangers like PHGMC the following technological operations are performed:

- RIH of the device as a part of a transport string liner;
- performing of washovers with limited pressure (no more than 75% of anchoring pressure);
- washover at the bottomhole without pressure limits (anchor actuation changes annular space insignificantly);
- performing of liner cementing with running of the cementing plug after the injection of the cement slurry for its separation from the displacement fluid;
- displacing the cement slurry to the outer annular space of the liner with limited displacement pressure after the suspended plug is cut off (no more than 75% of disconnection pressure) and receiving of " bump" signal;
- anchor unit actuation with internal overpressure build-up to 14 MPa;
- hydraulic breaking unit actuation with pressure build-up to 20 MPa;
- mechanical breaking unit actuation with transport string rotation to the right;
- packer unit actuation by partial uploading of the transport string weight onto the "head" part of the liner;
- washover and pulling out of the transport string.



PARAMETER DESCRIPTION	VALUE			
	PHGMC. 102/140- 85/117	PHGMC. 102/140- 89/119	PHGMC. 102/146	PHGMC. 114/168-102
Liner nominal diameter RIH with the device, mm	102	102	102	102
Nominal diameter of casing string which the device is run into and installed, mm	140	140	146	168
Maximum OD of the device body (at centralizer), mm	115 (117)	117 (119)	120 (122)	138 (141)
Min. drift diameter after actuation, mm	85	89	89	89
Maximum ID of a casing string in which anchoring is performed, mm	127	129	132	158
Values of controlling internal overpressure for actuation of units <sup>1</sup> , MPa				
- anchoring unit	18,5			14
- breaker unit	23,5			20
Maximum differential pressure between the zones isolated by the hydro-mechanical packer, MPa			30	
Maximum operating temperature <sup>2</sup> , °C			100	
Maximum tensile axial force on the body of a disconnection device <sup>3</sup> , kN	600	600	600	600
Connecting threads:				
- top GOST 28487 (GOST R 50864)	Z-86	Z-86	Z-102	Z-133
- bottom TR 14-161-163	OTTM-102	OTTM-102	OTTM-102	OTTM-102
Length in operating position, mm	3612	3687	3754	3769
Weight in operating position, kg	107,5	110	152	152

<sup>1</sup> Controlling overpressure values are given when all the shear bolts on the unit are used.

<sup>2</sup> Reference only, depends on operating conditions of general mechanical rubber goods in a well.

<sup>3</sup> Calculated value when stresses reach yield point of the material.



PARAMETER DESCRIPTION	VALUE			
	PHGMC. 114/168	PHGMC. 127/178- 114	PHGMC. 178/245- 114	PHGMC. 127/178
Liner nominal diameter RIH with the device, mm	114	114	114	127
Nominal diameter of casing string which the device is run into and installed, mm	168	178	245	178
Maximum OD of the device body (at centralizer), mm	138 (141)	150 (152)	211 (213)	150 (152)
Min. drift diameter after actuation, mm	99	99	99	111
Maximum ID of a casing string in which anchoring is performed, mm	158	160	231	160
Values of controlling internal overpressure for actuation of units <sup>1</sup> , MPa				
- anchoring unit			14	
- hydraulic disconnection device			20	
Maximum differential pressure between the zones isolated by the hydro-mechanical packer, MPa			30	
Maximum operating temperature <sup>2</sup> , °C			100	
Maximum tensile axial force on the body of a disconnection device <sup>3</sup> , kN	700	700	700	800
Connecting threads:				
- top GOST 28487 (GOST R 50864)	Z-102	Z-102	Z-102	Z-102
- bottom GOST 632-80	OTTM-114	OTTM-114	OTTM-114	OTTM-127
Length in operating position, mm	3769	3875	4265	3855
Weight in operating position, kg	152	213	400	196

<sup>1</sup> Controlling overpressure values are given when all the shear bolts on the unit are used.

<sup>2</sup> Reference only, depends on operating conditions of general mechanical rubber goods in a well.

<sup>3</sup> Calculated value when stresses reach yield point of the material.

PARAMETER DESCRIPTION	VALUE			
	PHGMC. 146/219	PHGMC. 178/245- 146	PHGMC. 168/245	PHGMC. 178/245
Liner nominal diameter RIH with the device, mm	146	146	168	178
Nominal diameter of casing string which the device is run into and installed, mm	219		245	
Maximum OD of the device body (at centralizer), mm	182 (184)		211 (213)	
Min. drift diameter after actuation, mm	129	129	150,5	157
Maximum ID of a casing string in which anchoring is performed, mm	196		231	
Values of controlling internal overpressure for actuation of units <sup>1</sup> , MPa				
- anchoring unit		16		14
- hydraulic disconnection device <sup>2</sup>		20		20
Maximum differential pressure between the zones isolated by the hydro-mechanical packer, MPa	30	15	15	15
Maximum temperature operating temperature <sup>2</sup> , °C			100	
Maximum tensile axial force on the body of a disconnection device <sup>3</sup> , kN			1000	
Connecting threads:				
- top GOST 28487 (GOST R 50864)	Z-133	Z-133	Z-133	Z-133
- bottom GOST 632-80	OTTM-146	OTTM-146	OTTM-168	OTTM-178
Length in operating position, mm	4010	4275	3769	4095
Weight in operating position, kg	319	400	385	380

<sup>1</sup> Controlling overpressure values are given when all the shear bolts on the unit are used.

<sup>2</sup> Reference only, depends on operating conditions of general mechanical rubber goods in a well.

<sup>3</sup> Calculated value when stresses reach yield point of the material.



## Protected hydro-mechanical cemented liner hanger **PHGMCZ**

Hydro-Mechanical Cemented Liner Hanger PHGMC with increased carrying capacity is designed for RIH, hanging and sealing in of a liner in a cemented well; performing of technological operations connected with cementing and sequential actuation of an anchor unit and a packer unit and further automatic disconnection of transport string from the liner and transport string pulling out.

PHGMCZ hanger is a complex of four stand-alone and independent units:

- hydraulic anchor;
- hydraulic release mechanism;
- mechanical packer;
- mechanical disconnection to back up hydraulic release mechanism.

The hanger is provided with a number of interlocks: hydraulic disconnection and hydraulic anchor are protected against early actuation before the hollow suspended plug is cut, the packer unit may be actuated only after disconnection.

The hanger consists of 2 parts: adjustment tool and the hanger itself, the latter includes packer unit, anchor unit and lead-in funnel.

When using hangers like PHGMCZ the following technological operations are performed:

- RIH of the device as a part of a transport string liner;
- washovers without pressure limitation;
- performing of liner cementing with running of the cementing plug after the injection of the cement slurry for its separation from the displacement fluid;
- displacing of the cement slurry to the outer annular space of the liner with limited displacement pressure after the suspended plug is cut off (no more than 75% of disconnection pressure) and receiving of "bump" signal;
- anchor unit actuation with internal overpressure build-up to 14 MPa;
- hydraulic breaking unit actuation with pressure build-up to 20 MPa; mechanical breaking unit actuation with transport string rotation to the right;
- packer unit actuation by partial uploading of the transport string weight onto the "head" part of the liner;
- washover and pulling out of the transport string.

PARAMETER DESCRIPTION	VALUE		
	PHGMCZ. 114/168	PHGMCZ. 127/178	PHGMCZ. 127/178-114
Liner nominal diameter RIH with the device, mm	114	127	114
Nominal diameter of casing string which the device is run into and installed, mm	168	178	178
Maximum OD of the device body (at centralizer), mm	143	150 (152)	150 (152)
Min. drift diameter after actuation, mm	99	111	99
Maximum ID of a casing string in which anchoring is performed, mm	157	167	167
Values of controlling internal overpressure for actuation of units <sup>1</sup> , MPa			
- anchoring unit		14	
- hydraulic disconnection device		20	
Maximum differential pressure between the zones isolated by the hydro-mechanical packer, MPa		30	
Maximum operating temperature <sup>2</sup> , °C		100	
Maximum tensile axial force on the body of a disconnection device <sup>3</sup> , kN		1000 (100)	
Connecting threads:			
- top GOST 28487 (GOST R 50864)	Z-102 OTTM-114	Z-102 OTTM-127	Z-102 OTTM-114
- bottom TR 14-161-163			
Length in operating position, mm	4059	4045	4065
Weight in operating position, kg	165	196	213

<sup>1</sup> Controlling overpressure values are given when all the shear bolts on the unit are used.

<sup>2</sup> Reference only, depends on operating conditions of general mechanical rubber goods in a well.

<sup>3</sup> Calculated value when stresses reach yield point of the material.



## Liner hanger with disconnection before cementing PHRC

Liner Hanger with disconnection before cementing PHRC is designed for RIH, hanging and liner sealing in the well.

The device is a complex of three stand-alone and independent units on the same body:

- anchor unit which ensures liner hanging in service string;
- mechanical packer unit which ensures sealing in of inner annular space;
- mechanical breaking unit which ensures RIH of units together with the liner, performance of technological operations such as washover, actuation of anchor unit, mechanical disconnection of the transport string from the device, liner cementing followed by packer unit actuation.

The hanger consists of two parts: adjustment tool and the hanger itself, the latter includes packer unit, anchor unit and lead-in funnel.

When using hangers like PHRC the following technological operations are performed:

- RHI of the device as a part of a transport string liner;
- washovers with limited pressure (no more than 75% of anchoring pressure);
- washover of the bottomhole without pressure limits (anchor actuation changes annular space insignificantly);
- ball-drop and its driving until its setting in the PGMC packer seat or in a special seat set above the check valve;
- PGMC actuation (for collar cementing);
- anchor unit actuation with internal overpressure build-up to 13 MPa;
- the pressure build-up to 16 MPa opens PGMC packer cementing ports (for collar cementing) or the pressure build-up to 20 MPa leads to shearing of a special seat with a ball to restore circulation;
- disconnection of an adjustment tool from the hanger through relief of the transport string and its rotation to the right at least 10 times;
- performing of liner cementing with running of the cementing plug after the injection of the cement slurry for its separation from the displacement fluid;
- displacing the cement slurry to the outer annular space of the liner and receiving of "stop" signal;
- packer unit actuation by partial uploading of the transport string weight onto the "head" part of the liner;
- washover and pulling out of the transport string.

PARAMETER DESCRIPTION	VALUE		
	PHRC. 102/140-89/119	PHRC. 102/146	PHRC. 114/168 -102
Liner nominal diameter RIH with the device, mm	102	102	102
Casing string nominal diameter which the device is RIH and installed, mm	140	146	168
Maximum OD of the device body (at centralizer), mm	117 (119)	120 (122)	138 (141)
Min. drift diameter after actuation, mm	89	89	89
Maximum ID of a casing string in which anchoring is performed, mm	127	132	158
Internal overpressure for anchoring unit actuation, MPa	13,0±5%		
Maximum swinging moment at the mechanical disconnection, kg*m	30–40		
Maximum tensile force <sup>1</sup> , kN	600		
Maximum pressure differential between the zones isolated by a packer unit, $\Delta P$ , MPa	30		
Maximum internal overpressure, MPa	25		
Maximum operating temperature <sup>2</sup> , °C	100		
Connecting threads: - top according to GOST 28487-90 - bottom according to TR 14-161-163-96	Z-86 OTTM-102	Z-86 OTTM-102	Z-102 OTTM-102
Length in operating position, mm	4478	4490	4686
Weight in operating position, kg	130,5	144,5	217

<sup>1</sup> Calculated value when stresses reach yield point of the material.

<sup>2</sup> Reference only, depends on operating conditions of general mechanical rubber goods in a well.

PARAMETER DESCRIPTION	VALUE		
	PHRC.114/168	PHRC. 127/178	PHRC.127/178 -114
Liner nominal diameter RIH with the device, mm	114	127	114
Casing string nominal diameter which the device is RIH and installed, mm	168	178	178
Maximum OD of the device body (at centralizer), mm	138 (141)	149 (152)	149 (152)
Min. drift diameter after actuation, mm	99	111	99
Maximum ID of a casing string in which anchoring is performed, mm	158	164	164
Internal overpressure for anchoring unit actuation, MPa	13,0±5%		
Maximum swinging moment at the mechanical disconnection, kg*m	30–40		
Maximum tensile force <sup>1</sup> , kN	700	800	700
Maximum pressure differential between the zones isolated by a packer unit, $\Delta P$ , MPa	30		
Maximum internal overpressure, MPa	25		
Maximum operating temperature <sup>2</sup> , °C	100		
Connecting threads: - top according to GOST 28487-90 - bottom according to TR 14-161-163-96	Z-102 OTTM-114	Z-102 OTTM-127	Z-102 OTTM-114
Length in operating position, mm	4670	4689	4709
Weight in operating position, kg	208,8	219,6	226,7

<sup>1</sup> Calculated value when stresses reach yield point of the material.

<sup>2</sup> Reference only, depends on operating conditions of general mechanical rubber goods in a well.



PARAMETER DESCRIPTION	VALUE	
	PHRCBT.140/178	PHRC.178/245
Liner nominal diameter RIH with the device, mm	140	178
Casing string nominal diameter which the device is RIH and installed, mm	178	245
Maximum OD of the device body (at centralizer), mm	151 (153)	211 (213)
Min. drift diameter after actuation, mm	125,4	159,4
Maximum ID of a casing string in which anchoring is performed, mm	160	232
Internal overpressure for anchoring unit actuation, MPa (PSI)	13,0±5%	
Maximum swinging moment at the mechanical disconnection, kg*m	30 – 40	
Maximum tensile force <sup>1</sup> , kN	700	100
Maximum pressure differential between the zones isolated by a packer unit, ΔP, MPa	70	
Maximum internal overpressure, MPa(PSI)	70	
Maximum operating temperature <sup>2</sup> , °C	100	
Connecting threads: - top according to GOST 28487-90 - bottom according to TR 14-161-163-96	Z-102 TMK-3	Z-133 OTTM-114
Length in operating position, mm(	3917	4390
Weight in operating position, kg	197,6	449

<sup>1</sup> Calculated value when stresses reach yield point of the material.

<sup>2</sup> Reference only, depends on operating conditions of general mechanical rubber goods in a well.



## Cemented liner hanger for flush-joint pipes **PHCBT**

Cemented Liner Hanger for flush-joint pipes PHCBT is applied for RIH and continuous cementing of a liner consisting of flush-joint pipes.

The PHCBT liner hanger consists of the top sub and the body joined with the bottom sub by special left-hand thread. There is a special groove in the body that holds the collet supported by the piston which is held by shear bolts. There is a suspended plug positioned within the inner channel of the device mounted with two hollow shear plugs.

The device operates as follows. While liner cementing top wiper plug is touching down the suspended plug seat and the shearing of two hollow plugs is performed due to the pressure build-up, the access of fluid to the plunger space is opened. The pressure build-up is performed after receiving the "stop" signal, shear bolts are ruined and plunger moves releasing a collet. Under tension the blades of the collet clench and therefore the liner is disconnected from the transport string.

The liner hanger is equipped with the mechanical breaking unit doubling the hydraulic one. It is actuated by transport string rotation to the right.

The device application area is vertical, tilting (flat) wellbores and bores with horizontal ends whereinto casing strings with diameter 102, 114, 120 and 140 mm are run in consisting of flush-joint pipes.

PARAMETER DESCRIPTION	VALUE			
	PHCBT. 102/140	PHCBT. 114/140	PHCBT. 120/146	PHCBT. 140/168
Liner nominal diameter RIH with the device, mm	102	114	120	140
Maximum OD of the device, mm	108	120	123	144
Drift diameter of the device, mm	86,5	98,5	105	124
Diameter of a hole in a plug seat, mm	30	40	40	40
Maximum internal pressure of the device body, MPa	25	25	25	25
Length of the device fully assembled, mm	2105	2105	2105	2105
Weight of the device, kg	45	78	73,35	78,1
Maximum tensile force <sup>1</sup> , kN (tn)	600 (60)	700 (70)	770 (77)	900 (90)
Maximum operating temperature <sup>2</sup> , °C	100	100	100	100
Connecting threads:				
- top GOST 633	73	73	73	73
- bottom TR 14-157-61-99	TMK-3	TMK-3	TMK-3	TMK-3

<sup>1</sup> Calculated value when stresses reach yield point of the material.

<sup>2</sup> Reference only, depends on operating conditions of general mechanical rubber goods in a well.



## Protected liner hanger for stage cementing PHZSC

Protected Liner Hanger for stage cementing PHZSC is applied for RIH, hanging and liner sealing in with two stage cementing. The hanger is used together with MMC1 sleeve or PGMC packer.

When using the device like PHZSC the following technological operations are performed:

- RHI of the device as a part of a transport string liner;
- performing of the 1st stage of continuous or collar cementing with the cementing plug running after the injection of the cement slurry for its separation from the displacement fluid;
- matching of the top cementing plug with the lower hollow cementing plug installed in the hanger;
- displacing the cement slurry to the outer annular space of the liner, removal of protection from the early actuation when passing the cementing plugs through the collar, receiving of the 1st stage "bump" signal and closing of the cementing ports;
- opening of the cementing ports by internal overpressure build-up at the depth of collar installation up to the opening pressure of cementing ports;
- flushing of the first stage cement slurry above the collar cementing ports;
- performing of the 2nd stage of liner cementing with the cementing plug running after the injection of the cement slurry for its separation from the displacement fluid;
- matching of the top cementing plug with the top hollow cementing plug installed in the hanger;
- displacing the cement slurry to the outer annular space of the liner, receiving of the 2nd stage "bump" signal and closing of the cementing ports;
- checking the collar ports closing by pressure relief to zero;
- internal overpressure build-up and consequential actuation of PHZSC hanger units – anchor, packers and liner disconnect – from the transport string;
- washover and pulling out of the transport string.
- drilling out of the cementing plugs and MMC collar seat after the end of WOC.

PARAMETER DESCRIPTION	VALUE	
	PHZSC. 102/146	PHZSC. 114/168
Liner nominal diameter equipped with the device, mm	102	114
Casing string nominal diameter which the device is RIH and installed, mm	146	168
Maximum OD of the device (at centralizer), mm	120 (122)	138 (141)
Drift diameter of the device (after actuation), mm	89	99
Minimal drift diameter at the top sub, mm	55	61
Maximum diameter of the circle circumscribed the extensible and sealing elements of the device in operating position, mm	159	159
Length in operating position, mm	3797	3816
Weight in operating position, kg	165	170
Maximum tensile force <sup>1</sup> , kN	600	700
Values of controlling internal overpressure for actuation of devices <sup>2</sup> , MPa		
- anchor unit		16
- packer unit		16
- breaking unit		20
Hollow suspended plugs shear pressure, MPa		4,0±5%
Maximum pressure differential between the zones isolated by a hydro-mechanical packer, MPa		15,0
Maximum operating temperature <sup>3</sup> , °C		100
Connecting threads:		
- top GOST 28487	Z-86	Z-102
- bottom GOST 632-80	OTTM 102	OTTM 114

<sup>1</sup> Calculated value when stresses reach yield point of the material.

<sup>2</sup> Controlling overpressure values are given when all the shear bolts on the unit are used.

<sup>3</sup> Reference only, depends on operating conditions of general mechanical rubber goods in a well.

<sup>4</sup> For device PHZSC.102/146 thread OTTM 102 is produced according to TR 14-161-163.

## Liner hanger assembly, revolving while cementing

### PHVC

Liner hanger assembly with rotation possibility while run in and also after disconnection while cementing. Disconnection (brake) is provided in two ways before cementing – hydraulically or mechanically.

Assembly is designed for high torque, heavy axial loads and allows to RIH BHA at any or very hard conditions.

BHA consists of separate modules: packer, anchor and setting tool.

BHA has several locks from pretriggering:

- Packer assembly is actuated after release and pulling out the setting tool and by partially unloading the weight of the drill string;
- Mechanically disconnection (brake) is made by a quarter turn of drill string counterclockwise;

Allows to perform the following operations:

- Run in the hole with drilling string rotating and rimming;
- Provide intermediate fluid (mud) circulation;
- Activation of the string starts after ball drop and pump it down to the shear saddle;
- Actuation of packer anchor are provided by pressure raise up to 140 atm and weight relief on the tailpipes;
- The brake-up of tail from the drill string is provided by pressure raise up to 180atm;
- The check of disconnection is provided by picking up the string and pressure drop;
- Run in back the string and pressure test;
- Restore the circulation by raising the pressure up to 220 atm for shearing the seat with the ball;
- Rotation of the liner while cementing;
- Cementing while run in the cement plug for dividing cement solution and squeeze mud;
- Attaching of cement plug to hollow hanger-plug installed in the string assembly;
- Receiving the Bump showing the squeezing cement is complete;
- Circulate to wash excess cement from the head of liner;
- Bring up to action the packer assembly and hanger with partially putting weight and unloading the string on thrust sleeve. The string meanwhile can be rotating.



PARAMETER DESCRIPTION	VALUE	
	PHVC.127/178	PHVC.127/178-114
Diameter of casing equipped with the tool, mm	127	114
Conditional Casing diameter where the tool is run in and set, mm	178	178
Max outside diameter of the tool as per body (a/p centralizer), mm	148	148
Drift diameter after actuation, mm, not less than...	112	99
Inner pressure when tension of tool parts reach the yield strength, MPA	87,5	87,5
Tensile load at which the body parts tensions are reaching the yield strength, kN	1956	1800
Max torque receiving through the string, kN/m	30	30
The values of internal excess pressures for actuating tool units, MPa: - anchor unit - breaker unit		14,0 18,0
Max differential pressure between divided by hydraulic /mechanical packer, MPa areas	70	70
Max operating temperature, °C	150	150
Connecting threads: - top Gov't Standard 28487 (R 50864) - bottom <sup>1</sup>	Z-102	Z-102

<sup>1</sup> The bottom thread is made as per Customer's tech request

## Liner Hanger with two kinds of release before cementing

### PHGMRC

PaLiner Hanger with two kinds of release before cementing is performed before cementing operation in two modes: hydraulically and mechanically.

Liner hanger consists of following individual hubs: packer, anchor and setting tool.

Assembly has a row of locks from premature response:

- Packer is actuated after release and pulling out of setting tool by partial putting on weight of the string;
- Mechanic release is provided by rotating the string clockwise.

This assembly allows provide the following operations:

- Run in the hole w/liner;
- Provide intermediate well circulation;
- Activation of assembly starts after drop and circulation of drop-ball down to the sitting saddle ;
- Actuating the anchor by pressure up to 140 atm and putting weight on the liner;
- Provide release the liner from the drill string by pressure up to 180 atm or by turning the string clockwise;
- Disconnection is checked out by picking up the string to ensure pressure drop;
- Run in back in the hole and pressure test;
- Restore the circulation by raising the pressure up to 220 atm to shear the seat with the ball;
- Cementing through top plug to separate cement and squeezing fluids;
- Attaching of cement plug to hollow hanger-plug installed in the string assembly;
- Attaching of top cement plug to hollow hanger-plug installed in the string assembly;
- displacing the cement slurry to the outer annular space of the liner and receiving of "Bump" signal;
- Circulate to wash excess cement solution from the top of liner;
- Actuation of liner packer assembly and hanger with partially putting weight and unloading the string on thrust sleeve.





PARAMETER DESCRIPTION	VALUE	
	PHGMRC 127/178-114	PHGMRC 178/245A
Conditional liner-pipe diameter equipped with the tool, mm	114	178
Conditional Casing diameter where the tool is run in and set, mm	178	245
Max outside diameter of the tool as per body (a/p centralizer), mm	149 (152)	211 (213)
Drift diameter after actuation, mm, not less than	99	158
Inner pressure when tension of tool parts reach the yield strength, MPA	700	700
Tensile load at which the body parts tensions are reaching the yield limit, kN	700	1500
The values of internal excess pressures for actuating tool units, MPa:		
- anchor unit		13,0
- breaker unit		18,0
Max differential pressure between divided by hydraulic /mechanical packer areas, MPa	70	300
Max operating temperature, °C	150	150
Connecting threads:		
- top Gov't Standard 28487 (R 50864)	Z-102	Z-133-
- bottom <sup>1</sup>		

<sup>1</sup> The bottom thread is made as per Customer's tech request



# PACKERS

Protected Hydraulic  
Packer

**PGRPZ**

**50**

Hydraulic Full-Bore  
Packer

**PGP, PGP1, PGP6**

**52**

Cross-flow Sealing  
Packer

**PGMP**

**54**

Hydraulic Full-Bore Packer  
with Small-Size Valve Unit

**PGPM1.245**

**56**

Hydraulic Packer for Collar  
Cementing

**PGMC, PGMC2,  
PGMC4, PGMC6**

**58**

Collar Cementing Packer

**PMC, PMC-R**

**62**

Water-Swellable and Oil-  
Swellable Packer

**PNV** and **PNN**

**64**



## Protected hydraulic packer **PGRPZ**

Protected Hydraulic Packer PGRPZ is applied for zonal isolation of open holes (or of the casing string) while performing different technological operations, including multistage hydraulic fracturing (MSHF).



PARAMETER DESCRIPTION	VALUE				
	102/118	102/136	114/136	114/144	114/148
CSG Passage Diameter (tail pipe) equipped with the Tool, mm	102		114		
Well bore Nominal Diameter (drill bit diameter) to run in, OD, mm	123,8	142,9	142,9	152,4	155,6
Drift diameter after actuation, mm, not less than	88		98		
Max tensile axial load on the body, kN	600		700		
Packer actuation inner overpressure. mPa - with all shear screws	17,5		18		
Maximum differential pressure, mPa			70		
Maximum internal overpressure, mPa			70		
Max operating temperature, °C			100		
Tool length in work position, mm	1416	1344	1610		
Tool weight in work position, kg	45	56	65	78	80
Connection thread : - top and bottom as per Gov't Standard - 632-80 and R	Thread type OTTM-102		Thread type OTTM-114		

## Hydraulic full-bore packer PGP, PGP1, PGP6

Hydraulic Full-Bore Packer for cross-flow prevention of PGP-type is applied to ensure reliable isolation of gas-, oil- and water-bearing formations.

The packer consists of two main units: sealing hose and valve unit. PGP, PGP1 and PGP6 are equipped with valve system with spring.

The packer works as follows: when the cementing plug is passing through the packer, it cuts off the female pin thus opening liquid access to the valve unit. This is how the preparation for actuation is done. After receiving the "bump" signal and pressure relief the preparation of valve system to the packer setting process is carried out and, followed by the pressure build-up in the string, the liquid passes from the casing string to the under-hose cavity. After the pressure relief in packers PGP, PGP1 and PGP6 the valve system switches and cuts off the liquid in the under-hose cavity keeping its volume under the hose.



PARAMETER DESCRIPTION	VALUE						
	PGP.89 (PGPU.89)	PGP.102/89 (PGPU.102/89)	PGP1.114 (PGPU1.114)	PGP.127	PGP6.146 (-01)	PGP1.168 (PGP6.168)	PGP.178
Casing string (liner) nominal diameter equipped with the packer, mm	89	102	114	127	146	168	178
Open borehole nominal diameter (bit diameter) which the packer is RIH, mm	120,6	124	146	152,4	215,9	215,9	215,9
Maximum differential pressure between the isolated zones at nominal packer setting coefficient, MPa	15						
Length of the well zone overlapped by a packer sealing element, mm	2900 (1200)		2900		1120 (2820)	1120	1120
Packer setting coefficient:							
-nominal	1,12	1,11	1,1	1,07	1,23	1,1	1,09
-maximum	1,25	1,3	1,3	1,25	1,45	1,4	1,4
Maximum operating temperature <sup>1</sup> , °C	100						
Maximum internal overpressure on the packer body, MPa	25						
Maximum tensile axial force on the body <sup>2</sup> , kN	500	600	700	800	850	1200	1100
Drift diameter, after actuation, mm	75,9	88	99	105,6	129	150,5	157
Outer diameter, mm	108	118	134	142	180	197	203
Length, not more:							
- in operating position, mm	5374 (3724)	5431 (3610)	5396 (3696)	5600	4088 (5908)	4503 (4423)	4247
Weight, not more:							
- in operating position, kg	108 (77,9)	137 (116)	124,7 (96,6)	178,6	185,6 (247)	220 (213)	250

<sup>1</sup> Reference only, depends on operating conditions of general mechanical rubber goods in a well.

<sup>2</sup> Calculated value when stresses reach yield point of the material.

## Cross-flow sealing packer PGMP

Cross-flow Sealing Packer of PGMP-type is applied to ensure reliable isolation of gas-, oil- and water-bearing formations in conditions where the well level is not at the wellhead.

The packer consists of two main units: sealing ring and protection unit against premature actuation.

The packer works as follows: when the cementing plug is passing through the packer, it cuts off the female pin opening thus liquid access to the thruster. This is how the preparation for actuation is done. After receiving the "bump" signal and string pressure build-up till the shear bolts failure level (which is set by selecting the required number of shear bolts before the packer RIH). The thruster starts to move deforming the sealing rings in the axial direction and pressing them against the borehole walls. The movement of the thruster is fixed by a latch.





PARAMETER DESCRIPTION	VALUE	
	PGMP.168	PGMP.245
Casing string (liner) nominal diameter equipped with the device, mm	102	114
Max. outer diameter, mm	123,8	142
Min. drift diameter after actuation, mm	150,5	224
Maximum tensile axial force on the body, kN <sup>1</sup>	1500	2000
Internal overpressure for packer actuation, MPa - with all shear bolts	20	15
Maximum pressure differential between the zones isolated by a packer, MPa	15	12
Maximum internal overpressure on the packer, MPa	25	20
Maximum operating temperature <sup>2</sup> , °C	100	
Length in operating position, mm	2331	2720
Weight in operating position, kg	163	337
Connecting threads: - top and bottom according to GOST 632-80 and GOST R 53365	OTTM-168	OTTM-245

<sup>1</sup> Reference only, depends on operating conditions of general mechanical rubber goods in a well.

<sup>2</sup> Calculated value when stresses reach yield point of the material.

## Hydraulic full-bore packer with small-size valve unit **PGPM1.245**

Hydraulic Full-Bore Packer for cross-flow prevention of PGPM1 for casing strings 245 mm is applied to ensure reliable isolation of gas-, oil- and water-bearing formations at any depth.

The packer PGPM1 consists of the following main units: body with mounted sealing rubberized fabric unit fixed by steel crimping cups, unit protecting packer from early actuation, valve unit body, valve unit and bottom sub.

The packer works as follows: during the cementing process the cementing plug is passing through the packer interior cavity and cuts off hollow shear pins with a sealing ring thus opening liquid access to the packer valve unit. After receiving the "bump" signal and pressure relief the valve is switched and the preparation of valve system to the packer setting process is carried out and, followed by the pressure build-up in the string, the liquid passes to the under-hose cavity. The overpressure build-up to 6-8 MPa at the packer setting depth leads to inflation of the sealing element which is pressed to the borehole walls hermetically. After the pressure relief the valve system switches and cuts off the liquid in the under-hose cavity keeping its volume under the hose.



PARAMETER DESCRIPTION	VALUE	
	PGPM1. 245B	PGPM1. 245VG
Outer diameter, mm	280	
Drift diameter, after actuation, mm	224	
Length of the well zone overlapped by a packer sealing element, mm	2080	
Packer setting coefficient:		
- nominal	1,11	
- maximum	1,24	
Maximum differential pressure between the isolated zones at nominal packer setting coefficient, MPa	15	
Maximum internal overpressure on the packer body, MPa	15	28
Maximum external overpressure on the packer body, MPa	12	15
Maximum tensile axial force on the packer body <sup>1</sup> , kN	2000	
Maximum operating temperature <sup>2</sup> , °C	100	
Length, not more:		
- in operating position, mm	5350	5520
Weight, not more:		
- in operating position, kg	501	
Reliability coefficient, not less	0,95	

<sup>1</sup> Calculated value when stresses reach yield point of the material.

<sup>2</sup> Reference only, depends on operating conditions of general mechanical rubber goods in a well.

## Hydraulic packer for collar cementing **PGMC, PGMC2, PGMC4, PGMC6**

Hydraulic Packer for Collar Cementing PGMC is applied for collar cementing and to ensure separation of filtering and cementing parts of liners and isolation of gas-, oil- and water-bearing formations.

The packer PGMC consists of two devices combined in one body: a hydraulic packer and a cementing collar. The collar part of the device is the system of mechanically interconnected bushes fixed on shear bolts that overlap cementing slots and the entrance to the under-hose cavity. The design of the packing part is similar to the design of PGP packer.

The packer works as follows: before cementing, a ball is dropped into the transport string and pumped until setting down a seat. With pressure build-up to  $4,0 \text{ MPa} \pm 10\%$  bolts are sheared off and the plug is moved down until bumping the shoulder thus opening liquid access to the valve system of the device packer part. After that the pressure is dropped down to 0 and the valve system prepares the packer to actuation. On subsequent pressure build up to 6-8 MPa the hose inflates separating hermetically cementing and noncementing parts of the liner in the outer annular space. The following pressure relief to 0 switches the valve system and shuts liquid access to the packer part of the device.

PGMC2 and PGMC4 packers work in the similar way, but they do not require pressure release for preparation of the valve system for packer setting.

The next cycle of the pressure build-up to 16 (14,5; 14) MPa opening of cementing ports is performed. After mixing and displacing of cement slurry, the hollow cementing plug (together with the top cementing plug) is set down to the seat and after the internal overpressure build up to 5 MPa it closes cementing ports and fixes its position.



PARAMETER DESCRIPTION	VALUE						
	PGMC.89 (PGMCU.89)	PGMC.102/89 (PGMCU.102/89)	PGMC6.114 (PGM- CU6.114)	PGMC.127	PGMC6.146	PGMC1.168	PGMC.178
Casing string nominal diameter equipped with the packer, mm	89	102	114	127	146	168	178
Open borehole nominal diameter (bit diameter) which the packer is RIH, mm	120,6	123,8	146	152,4	215,9	215,9	215,9
Maximum pressure differential between the isolated zones at nominal packer setting coefficient, MPa				15			
Length of the well zone overlapped by a packer sealing element, mm	2900 (1200)			2900	1120		
Internal overpressure of cementing ports opening <sup>1</sup> , MPa ± 10%	16	16	15,9	15	15	16	15,6
Internal overpressure of cementing ports closing <sup>1</sup> , MPa ± 10%	5,0	3	2,9	3,0	2,6	2,5	2,5
Packer setting coefficient:							
- nominal	1,12	1,11	1,11	1,11	1,18	1,13	1,13
- maximum	1,25	1,3	1,35	1,3	1,45	1,3	1,35
Maximum operating temperature <sup>2</sup> , °C				100			
Maximum tensile axial force on the body <sup>3</sup> , kN	500	600	700	800	850	1200	950
Drift diameter, after actuation, mm	75,9	88	98,5	105,6	129	150,5	157
Outer diameter, mm	108	118	134	142	180	197	203
Length, not more:							
- in operating position, mm	5588 (3938)	5660 (3805)	5645 (3945)	5660	5923	5279	5404

<sup>1</sup> Controlling overpressure values are given when all the shear bolts on the unit are used.

<sup>2</sup> Reference only, depends on operating conditions of general mechanical rubber goods in a well.

<sup>3</sup> Calculated value when stresses reach yield point of the material.

PARAMETER DESCRIPTION	VALUE		
	PGMC2. 102/89	PGMC4.102 (PGMCU4.102)	PGMC4.114 (PGMCU4.114)
Casing string nominal diameter equipped with the packer, mm	102		114
Open borehole nominal diameter (bit diameter) which the packer is RIH, mm	124		146
Maximum differential pressure between the isolated zones at nominal packer setting coefficient, MPa		15	
Length of the well zone overlapped by a packer sealing element, mm	70*	3000 (1200)	3000 (1200)
Internal overpressure of cementing ports opening <sup>1</sup> , MPa ± 10%		16	
Internal overpressure of cementing ports closing <sup>1</sup> , MPa ± 10%	3		5
Packer setting coefficient:			
- nominal	1,06	1,07	1,14
- maximum	1,29	1,25	1,25
Maximum operating temperature <sup>2</sup> , °C		100	
Maximum tensile axial force on the body <sup>3</sup> , kN		25	
Drift diameter, after actuation, mm		25	
Outer diameter, mm	600	600	600
Length, not more:			
- in operating position, mm	89	85	95
Outer Diameter, mm	118	116	128
Length, not more:			
- in operating position, mm	2836	5200 (3500)	5271 (3571)

<sup>1</sup> Actuation pressure with all shear bolts.

<sup>2</sup> Reference only, depends on operating conditions of general mechanical rubber goods in a well.

<sup>3</sup> Calculated value.

<sup>4</sup> Calculated value when stresses reach yield point of the material.

\* PGMC2.102 packer unit is hydro-mechanical and has two sealing rings.



## Collar cementing packer PMC, PMC-R

Collar Cementing Packer PMC is applied to ensure separation for cemented and noncemented casing string parts (liner) during collar cementing. The packer is used together with collar cementing valve KMC.

The packer is produced in two designs, PMC and PMC-R that differ in the type of a sealing element:

- in PMC a sealing element consists of three sealing rings;
- in PMC-R a sealing element is a rubberized fabric hose.

The packer is actuated before cementing by a ball-drop and its pumping until setting down a seat inside the packer. This leads to the deformation of a sealing element and packing of annular space between the walls of a well and a casing string (liner).

The packer is equipped with a trip valve which ensures RIH without overflow.



PARAMETER DESCRIPTION	VALUE	
	PMC.102	PMC-R.102 (PMCU-R.102)
Outer diameter, mm	118	
Drift diameter, after actuation, mm	88	
Length of the well zone overlapped by a packer sealing element, mm	280	2800 (1200)
Packer setting coefficient:		
- nominal	1,06	1,11
- maximum	1,29	1,3
Maximum pressure differential between the isolated zones at nominal packer setting coefficient, MPa	15	
Maximum internal overpressure on the packer body, MPa	25	
Maximum tensile axial force on the packer body <sup>1</sup> , kN	600	
Maximum operating temperature <sup>2</sup> , °C	100	
Length, not more:		
- in operating position, mm	1416	4991 (3291)
Weight, not more:		
- in operating position, kg	45	104 (91)
Reliability coefficient, not less	0,95	

<sup>1</sup> Calculated value when stresses reach yield point of the material.

<sup>2</sup> Reference only, depends on operating conditions of general mechanical rubber goods in a well.



## Water-swellable and oil-swellable packer **PNV** and **PNN**

"NTC "ZERS" LLC has developed different packer models in which the sealing element is made of elastomeric material that is able to swell out on contact with certain fluid (water or oil).

Swellable packers have the following significant advantages:

- secure and irreversible beds isolation at well construction;
- packer design doesn't include valve systems and moving parts which can cause the packer failure;
- there is no need in special operations and special running tool for their installation in the well;
- ability to self-healing and recovery of the sealing properties.

Packers with elastomeric material which swell in hydrocarbon medium are marked as PNN, and packers with elastomeric material which swell in water medium are marked as PNV. PNV and PNN packers can be installed with the casing string as well as in the hole open bore, they can be applied at various stages of well construction including fixing of the lateral holes as the redundant device for increasing of lateral holes fixing quality at the space between a liner hanger and a port made in a production string.

Packers with sealing elements made of swellable elastomeric materials can also be used for effective and secure beds isolation at construction of horizontal and multilateral wells, for improvement of cementing quality, in complexes for controlled zonal isolation with FSO filters and KRR devices, as well as in many other operations at wells fixing and zonal isolation.

PNV and PNN swellable packer models are designed for space isolation in an open hole or in a casing string.

PARAMETER DESCRIPTION	PNV AND PNN PACKER TYPICAL SIZE							
	60/85	73/94	102/118	102/124	114/136	114/144	114/148	127/148
Liner nominal diameter on which the packer is RIH, mm	60	73	102	102	114	114	114	127
Recommended wellbore diameter which the packer is installed in, mm	89	99	124÷128	132	143÷146	152÷156	156÷160	156÷160
Maximum pressure differential on the packer, MPa	7,5	7,5				70		
Elastomeric material length, mm	850	850				1200		
Packer length, mm	1600	1600				2600		
Packer outer diameter, mm	85	94	118	124	136	144	148	148
Weight, kg	20	27	58	61	72	75	78	81
Maximum operating temperature, °C	100							
Estimated packer swelling time for full isolation of the well space <sup>1</sup> , days		5...7				7...9		

<sup>1</sup> Parameters values are shown for the rated hole diameter on the base of used swelling resins types and well conditions (temperature, well fluid type on running down and operation, etc.).





# EXTERNAL CASING ATTACHMENTS

Collar for Collar  
Cementing

**MMC1**

**70**

String Disconnect for  
Water Wells

**RKVS**

**72**

Multiple-Unit Rotating  
Disconnect

**RKVO**

**74**

Collar Cementing Valve

**KMC**

**76**

Cementing Basket

**CK**

**77**

Pressure Test Device

**PO**

**78**

Stage-by-stage Casing  
Running Tool

**USSK, USSKP**

**80**

Hydraulic Fracturing  
Sealing Assembly

**UGRH**

**82**

Screener

**UECS**

**84**

Ball Check Valve

**KOSH2, KOSHBT**

**86**

Seat-Trap

**SL**

**90**

Auxiliary Top  
Modular Packer

**PDV-M**

**91**

Top Auxiliary Packer

**PDV2**

**92**

Trip Stop-Tap

**SPD-2**

**94**

Bow-Spring Centralizer

**PC**

**96**

Hard Elastic Centralizer

**PCR**

**98**

Low-frictional Turbulence  
Generating Centralizer

**CTN**

**99**

Stop Ring

**SKC**

**100**

Cementing  
Throttle Check Valve

**CKOD**

**101**

Casing Shoe

**BK**

**102**

Well screener

**FS, FB**

**106**

EXTERNAL CASING  
ATTACHMENTS





## Collar for collar cementing MMC1

Collar for Collar Cementing is applied for two-stage or collar cementing of casing strings or liners with diameter 102, 114, 127, 140, 146, 168, 178 and 245 mm.

While using a collar like MMC1 the following process operations are performed:

- performance of the first stage of casing cementing with start of the first cementing plug after pumping in of cement slurry;
- displacing the cement slurry to the outer casing annular space until receiving the "bump" signal;
- internal overpressure build-up and opening of cementing ports in a collar;
- flushing of extra cement slurry of the first stage;
- performance of the second stage of casing cementing with start of the second cementing plug after pumping in cement slurry;
- displacing of the second stage cement slurry to the outer casing annular space until receiving the "bump" signal;
- collar ports closing by the internal overpressure build-up.



The 1st cementing plug



The 2nd cementing plug

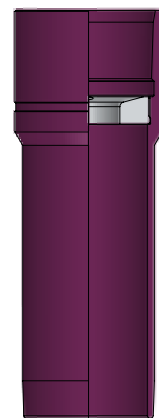

Stop-tap



PARAMETER DESCRIPTION	VALUE							
	MMC1.102	MMC1.114	MMC1.127	MMC1.140	MMC1.146	MMC1.168	MMC1.178	MMC1.245
Casing string nominal diameter equipped and RIH with the collar, mm	102	114	127	140	146	168	178	245
Open borehole nominal diameter (bit diameter) which the collar is run in, mm	124	142,9	155,6	190,5	190,5	215,9	215,9	295,3
Maximum outer diameter, mm	120	136	148	172	178	197	204	282
Drift diameter, after actuation, mm	88	98	110	124	130	150	158	220
Internal overpressure of cementing ports opening <sup>1</sup> , MPa ± 10%	16,0	16,0	14,0	16,0	16,0	16,0	16,0	14,0
Internal overpressure of cementing ports closing <sup>1</sup> , MPa ± 10%	3,5	2,2	2,0	4,0	5,0	5,0	4,0	3,5
Maximum operating temperature <sup>2</sup> , °C	100							
Maximum internal overpressure on the collar housing, MPa	25							
Maximum external overpressure on the collar housing <sup>3</sup> , MPa	35,0	35,0	18,0	18,0	18,0	18,0	18,0	19,0
Maximum tensile axial force on the collar housing <sup>3</sup> , kN	600	700	800	1000	1000	1200	1200	2300
Length in operating position, mm	1013	1990	2299	2865	2865	2888	2865	2333
Weight in operating position, kg	29,1	67,5	95	118	122	134	150	265

<sup>1</sup> Actuation pressure with all the shear bolts.

<sup>2</sup> Reference only, depends on operating conditions of general mechanical rubber goods in a well.

<sup>3</sup> Calculated value.



## String disconnect for water wells **RKVS**

Disconnect RKVS is used to disconnect the transport string while RIH the flush casing (liner). RKVS is applied in holes with casing strings which diameter is 245 and 324 mm where liners of casing pipes with diameter 168 mm are run in.

While using a disconnect RKVS the following process operations are performed:

- the disconnect RKVS and the provided tool set (accessories) are run in as a part of a liner 168 mm on a flush transport pipe string with inner diameter not less than 150 mm or on drill string 5";
- performance of the liner cementing with start of the cementing plug after pumping in of cement slurry for its separation from the displacement fluid;
- displacing the cement slurry to the outer casing annular space until receiving the "bump" signal;
- disconnect off-loading (setting) on funnel which has been mounted in a casing string 324 mm;
- liner disconnection from the transport string by mechanical rotation of the string to the right;
- washover and transport string pulling out.

Disconnect operating medium is drilling mud and cementing slurry treated by chemical reagents, oilfield brine, oil and gas at 100 °C temperature.

PARAMETER DESCRIPTION	VALUE	
	RKVS.168/324	RKVS.168/245
Diameter of casing equipped w/device,(mm)	168	168
Relative CSG size (ID) for running in and setting releaser, mm	324	245
Max Releaser OD, mm	206	206
Releaser Length w/ suspended plug, not more than (mm)	943	858
Releaser Weight w/ suspended plug, not more than (kg)	99,5	87,1
Max Tension kN (tN)	700(70)	700(70)
Max inside Pressure on device body, Mpa	25,0	25,0
Max operating temperature, °C	100	100
Connecting threads: <sup>1</sup> – top and bottom as per Gov't Standard 632-80	OTTM 168 OTTM 168	Z-133 <sup>2</sup> OTTM 168

<sup>1</sup> Connecting Threads type approved by Customer

<sup>2</sup> Threads are cut as per Gov't Standard 28487-90



## Multiple-unit rotating disconnect RKVO

Disconnect RKVO is applied for sectional running in of a casing string 168 mm with the option of reaming with rotation and washing out during the first section RIH.

While using a disconnect RKVO 168 the following process operations are performed:

- the disconnect RKVO and the provided tool set (accessories) are run in as a part of a liner 168 mm on a drill pipe string with inner diameter not less than 100 mm;
- reaming with rotation to the right and washing out if necessary;
- performance of the liner cementing with start of the cementing plug after pumping in of cement slurry for its separation from the displacement fluid;
- displacing the cement slurry to the outer casing annular space until receiving the "bump" signal;
- hydraulic disconnection of the section from the drill string through internal overpressure build-up;
- mechanical disconnection by string rotation to the right if hydraulic disconnection is impossible;
- washover and drill string pulling out;
- the second section running in and hermetical connection to the first section;
- cementing ports opening in MMC1.168 collar and the second section cementing with a cementing plug start and closing of ports after receiving the "bump" signal.

PARAMETER DESCRIPTION	VALUE
Liner nominal diameter equipped with the device, mm	168
Disconnect maximum outer diameter, mm	203
Drift diameter, after actuation, mm	150
Disconnect length, not more than, mm	1375
Disconnect weight, not more than, kg	171
Maximum tensile force, kN (tn)	1300 (130)
Maximum torque, kN*m	15
Disconnect unit actuation pressure, MPa	18,5
Maximum swinging moment at mechanical disconnection, kg*m	50-70
Maximum internal pressure on the device body, MPa	25,0
Maximum operating temperature <sup>2</sup> , °C	100
Connecting threads: - top according to GOST 632-80 - bottom	Z-133 TMK UP CWB 168

<sup>1</sup> Connecting thread type is agreed with Customer.



## Collar cementing valve KMC

Collar Cementing Valve is applied for collar cementing of liners and is used as a whole with the packer PMC or PMC-R.

The valve opens hydraulically by pressure build-up. The valve closes automatically at any moment when outer annular pressure is higher than pipe pressure. Final valve closing and fixation in the set position are performed when a cementing plug is set into a seat in the valve.

PARAMETER DESCRIPTION	VALUE	
	KMC.102	KMC.114
Liner nominal diameter equipped with the device, mm	102	114
Open borehole diameter which the device is run into and installed, mm	123,8-124	142,9
Maximum outer diameter of the device, mm	118	130
Drift diameter of the device (after disconnection), mm	88	99
Length of the device fully assembled, mm, not more	594	670
Device weight, kg, not more than	15,4	20,7
Maximum tensile force at which the stresses in the body parts reach the yield point <sup>1</sup> , kN (tn)	600 (60)	700 (70)
Cementing ports opening pressure <sup>2</sup> , MPa ±10%	16,0	
Maximum operating temperature <sup>3</sup> , °C	100	
Connecting threads <sup>4</sup> :		
- top according to TU 14-161-163-96 (GOST 632-80)	OTTM 102	OTTM 114
- bottom according to TU 14-161-163-96 (GOST 632-80)	OTTM 102	OTTM 114

<sup>1</sup> Calculated value when stresses reach yield point of the material.

<sup>2</sup> Actuation pressure with all shear bolts.

<sup>3</sup> Reference only, depends on operating conditions of general mechanical rubber goods in a well.

<sup>4</sup> Connecting thread type is agreed with the Customer.



## Cementing basket CK

Cementing Basket is used to create a platform for sedimentation of cement slurry filling outer annular space outside a casing diameter 102, 114, 127, 140, 146, 168 and 178 mm.

During cement slurry squeezing a cementing plug goes through the inner hollow of the device and disengages the early actuation protection. After receiving the "bump" signal and the check valve leakage test the internal pressure is build-up to the actuation pressure of the device preset before the device RIH. Shear bolts are destroyed and actuation starts. Petal shell is outstretched and touches the hole wall thus constructing a base for sedimentation of cement slurry solid phase. Condensed cement connecting strip is formed by itself on it thus preventing lowering of the cement slurry column in the hole.

PARAMETER DESCRIPTION	VALUE						
	CK.102/140	CK.114	CK.127	CK.140	CK.146	CK.168	CK.178
Maximum outer diameter, mm	117	130	144	163	170	193	200
Casing string diameter equipped and RIH with the device, mm	101,6	114,3	127	139,7	146,1	168	178
Drift diameter, after actuation, mm	89	99	112	126	127	150	162
Device actuation pressure <sup>1</sup> , MPa	16	16	16	16	16	16	16
Maximum diameter of basket opening, mm	185	195	195	205	240	250	260
Length, mm	955	1050	1050	1150	1150	1150	1150
Weight, kg, not more	29	31	34	52	55,5	65,5	69
Maximum operating temperature <sup>2</sup> , °C	100	100	100	100	100	100	100

<sup>1</sup> Actuation pressure when all the shear bolts.

<sup>2</sup> Reference only, depends on operating conditions of general mechanical rubber goods in a well.

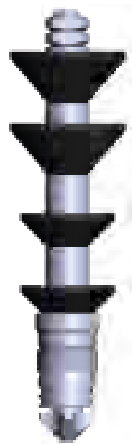

# Pressure test device

## PO

The Pressure Test Device is applied for drill string or tubing string pressure testing and gaging. The device is included into the drill string during well bore preparation to casing string running in. It is installed at the adjusted depth. After all the necessary elaborations and flushing a plug is started at the bottomhole. After the drill string volume pumping up to PO the plug is set into a seat. Drill string pressure testing is performed with gradual pressure build-up. When the pressure  $25,0 \pm 2,5$  MPa is reached shear bolts are cut off and a bush is moved against the bottom sub butt thus opening ports in the body.

The produced modification PO2 has a significantly lower hydraulic hammer effect with wash-out ports opening.



EXTERNAL CASING ATTACHMENTS

PARAMETER DESCRIPTION	VALUE			
	PO-NKT 73	PO-NKT B-73	PO.000	PO.102
Drill string nominal diameter RIH with the device, mm	73	73	73; 89	73; 89
Maximum outer diameter of the device, mm	89	93,2	121	105
Drift diameter of the device, mm	30	30	40	30
Maximum internal overpressure, MPa $\pm 10\%$	30,0			
Length of the device fully assembled, mm	830	830	857	911
Device weight, kg, not more	28,3	31,4	59	51
Maximum tensile FORCE1, kN (tn)	2000 (200)			
Washout ports opening pressure <sup>2</sup> , MPa $\pm 10\%$	25			
Maximum operating temperature <sup>3</sup> , °C	100			
Connecting threads: (top and bottom) according to GOST R 50864-90 (TU 3668-00-7-1403-00-39-2005)	73 GOST 633	B-73 GOST 633	Z-102	Z-86 (Z-83)

<sup>1</sup> Calculated value when stresses reach yield point of the material.

<sup>2</sup> Actuation pressure with all the shear bolts.

<sup>3</sup> Reference only, depends on operating conditions of general mechanical rubber goods in a well.



PARAMETER DESCRIPTION	VALUE		
	P02.102	P0.114	P0.127
Drill string nominal diameter RIH with the device, mm	73, 89	114	127
Maximum outer diameter of the device, mm	105	158,8	158,8
Drift diameter of the device, mm	30	55	55
Maximum internal overpressure, MPa $\pm 10\%$	30	30	30
Length of the device fully assembled, mm	826	1437	1091
Device weight, kg, not more	42,2	155,3	118,3
Maximum tensile FORCE <sup>1</sup> , kN (tn)	2000 (200)		
Washout ports opening pressure <sup>2</sup> , MPa $\pm 10\%$	25	25	25
Maximum operating temperature <sup>3</sup> , °C	100		
Connecting threads:(top and bottom) according to GOST R 50864-90 (TU 3668-00-7-1403-00-39-2005)	Z-86 Z-83	Z-122 (Z-133)	Z-133

<sup>1</sup> Calculated value when stresses reach yield point of the material.

<sup>2</sup> Actuation pressure with all the shear bolts.

<sup>3</sup> Reference only, depends on operating conditions of general mechanical rubber goods in a well.



## Stage-by-stage casing running tool USSK, USSKP

Stage-by-stage RIH of liners appeared firstly as a practical solution for the problem of casing strings running into wells with intensive curvature and (or) long horizontal section thus there is always a risk not to reach the target depth while running in a liner. Secondly it appeared as a possibility to perform a liner collar cementing at a given interval by cementing its second section.

The stage-by-stage-casing (liners) running tool USSK is intended for running in of a liner first (lower) section on drill pipes without its cementing with further running in, leaktight connection of the liner second section followed by cementing of the second section. USSK is threaded onto the upper pipe of the liner first section and is RIH on drill pipes.

USSK consists of two principal units: hydraulic disconnection unit to disconnect the liner from a transport string and mechanical disconnection (back off) unit to disconnect the liner from a transport string implemented in a single tool. After liner running into the adjusted depth and a ball is dropped into the transport string and pumped until setting down a seat. Pumping screws are cut by the pressure build-up to 14 MPa and the liner hydraulic disconnection unit is actuated. If there is no possibility for the internal overpressure build-up, the disconnection is performed by rotating (20 rotations) of the transport string to the right.

### *The stage-by-stage-casing (liners) running tool with packer sealing USSKP.*

The USSKP consists of three principal tools: hydraulic inflatable packer unit, hydraulic disconnection unit to disconnect the liner from the transport string and mechanical disconnection (back off) unit to disconnect the liner from the transport string implemented in a single tool.

PARAMETER DESCRIPTION	VALUE	
	USSK.102	USSK.114
Liner nominal diameter equipped with the device, mm	102	114
Open borehole diameter which the device is run into and installed, mm	123,8-124	142,9
Maximum outer diameter of the device, mm	118	132
Drift diameter of the device (after disconnection), mm	88	99
Length of the device fully assembled, mm, not more	2381	2416
Device weight, kg, not more	60	98,1
Maximum tensile force at which the stresses in the body parts reach the yield POINT1, kN (tn)	600 (60)	700 (70)
Disconnection unit actuation pressure <sup>2</sup> , MPa ±10%	13,0	
Maximum operating temperature <sup>3</sup> , °C	100	
Connecting threads <sup>4</sup> :		
- top according to GOST 28487-90	Z-86	Z-102
- bottom according to TU 14-161-163-96 (GOST 632-80)	OTTM 102	OTTM 114

<sup>1</sup> Calculated value when stresses reach yield point of the material.

<sup>2</sup> Actuation pressure with all shear bolts.

<sup>3</sup> Reference only, depends on operating conditions of general mechanical rubber goods in a well.

STABBING SHOE	USSK.102.100	USSK.114.100
Maximum outer diameter of the device, mm	117	127
Drift diameter of the device, mm	88	99
Minimum load for the device actuation, kg ±10%	2000	2000
Maximum spring to check casing string sections joining, kg	5000	5000
Length of the device fully assembled, mm, not more	250	280
Device weight, kg, not more	6,1	6,4
Top connecting thread according to TU 14-161-163-96 (GOST 632-80)*	OTTM 102	OTTM 114

\* Connecting thread type is agreed with Customer.

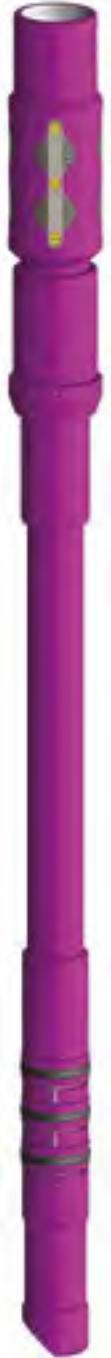

## Hydraulic fracturing sealing assembly UGRH

Sealing assembly UGHR is applied for protection of production string with nominal diameter 146, 168 and 178 mm from overpressure due to hydraulic fracturing.

The device is used in wells cased with liners diameter 102, 114 and 127 mm run in with hangers PHCZ, PHGMC or PHRC with drift pass inner diameter 89, 99 and 111 mm respectively.

Index "N" in UGRH titles is used to mark a device mounted at a liner hanger head. This device has larger pass comparing to UGRH mounted at the bottom sub.

Hydraulic Fracturing Sealing Assembly UGRH has the following advantages:

- adjustable and easy to use design;
- installation of the device doesn't require any operations with tubing and overpressure at the wellhead;
- self-sealing elements of the sealing unit hold significant pressure differentials;
- large drift pass allows large-volume hydrofracturing performance and reduces abrasive wear of inner parts surface.

The device consists of a hydraulic anchor, a sub with conical back nut, an extension pipe, a sealing unit and a guide shoe.

PARAMETER DESCRIPTION	VALUE								
	UGRH.102/140	UGRH.102/146	UGRH.114/168-102	UGRH.114/168	UGRH.127/178-114	UGRH.127/178	UGRH.102/146H	UGRH.114/168H	UGRH.127/178H
Production string nominal diameter for anchor installation, mm	140	146	168	168	178	178	146	168	178
Inner diameter of hanger mounting seat for installation of a sealing unit, mm	85	89	89	99	99	111	108	122	135
Anchor outer diameter, mm	118	122	141	141	148	148	122	141	148
Drift diameter after actuation, mm	60	60	60	76	76	76	76	96	96
Maximum pressure differential, MPa					70				
Maximum operating temperature <sup>1</sup> , °C					100				
Connecting thread according to GOST 633-80					89				

<sup>1</sup> Reference only, depends on operating conditions of general mechanical rubber goods in a well.



## Screener UECS

UECS is a screener to limit sedimentation processes in cement slurry filling casing outer annulus in a well behind the casing diameter 245, 324 and 426 mm.

UECS device includes a spring petal shell interacting with a screening element which is an easily deformable rubber petal collar. Assembly fixture is implemented as bolts with sharpened end which penetrate the casing pipe surface when screwed in.

When cementing is finished the petal collar and the screener shell are in close contact with each other and with well walls (the noncircular one) and form a base for sedimentation of solids from cement slurry. Condensed cement connecting strip is formed by itself on it thus along with the screener preventing lowering of the cement slurry column in the hole.

PARAMETER DESCRIPTION	VALUE		
	UECS.245	UECS.324	UECS.426
Maximum outer diameter, mm	400	484	600
Casing string diameter, mm	245	324	426
Length, mm	343	320	360
Weight, kg	14,5	15	16
Maximum operating temperature <sup>1</sup> , °C	100		

<sup>1</sup> Reference only, depends on operating conditions of general mechanical rubber goods in a well.





## Ball check valve **KOSH2, KOSHBT**

Ball Check Valve KOSH-type is applied for prevention of backflow of cement slurry or drilling mud from outer annulus into inner space of a casing string with nominal diameter 89, 102, 114 and 127 mm.

Ball Check Valve KOSH2 is used in wells where casings (liners) with nominal diameter 89, 102, 114 and 127 mm are run in. Ball Check Valve KOSHBT is used in wells which collarless casings with nominal diameter 102, 114, 120 and 140 mm are run in. Inner parts of KOSH valves are made of aluminium alloy.

It is possible to mount KOSH2.114 and KOSH2.127 valves on pipes with thread OTTG 114 and OTTG 127, GOST 632-80.



PARAMETER DESCRIPTION	VALUE			
	KOSH2.89	KOSH2.102	KOSH2.114	KOSH2.127
Casing string nominal diameter RIH with the device, mm	89	102	114	127
Maximum outer diameter of the device, mm	108	110	127	141,3
Drift diameter of the device, mm	76	89	99	111
Ball diameter, mm	46	46	55	55
Maximum internal pressure on the valve body, MPa	25			
Maximum pressure differential maintained by the valve in bottom-top direction, MPa	10			
Length of the device fully assembled, mm	400	380	404	420
Device weight, kg, not more	9,2	9,2	12,8	16,8
Maximum tensile force <sup>1</sup> , kN (tn)	600 (60)		700 (70)	800 (80)
Maximum operating temperature, °C	100			
Connecting threads <sup>2</sup> , - top and bottom according to GOST 632-80	NKT89	OTTM102	OTTM114	OTTM127

<sup>1</sup> Calculated value when stresses reach yield point of the material.

<sup>2</sup> For KOSH2.89 valve the thread is produced according to GOST 633-80.

For KOSH2.102 valve the thread is produced according to TR 14-161-163-96.

PARAMETER DESCRIPTION	VALUE			
	KOSHBT. 102	KOSHBT. 114	KOSHBT. 120	KOSHBT. 140
Casing string nominal diameter RIH with the device, mm	102	114	120	140
Maximum outer diameter of the device, mm	103,2	115,2	121,5	140,5
Drift diameter of the device, mm	86,5	98,5	105	124
Ball diameter, mm	46		55	
Valve seat hole diameter, mm	30		40	
Maximum internal pressure on the valve body, MPa			25	
Maximum pressure differential maintained by the valve in bottom-top direction, MPa			10	
Length of the device fully assembled, mm			450	
Device weight, kg, not more	9,4	11,2	11,97	14,6
Maximum tensile force <sup>1</sup> , kN (tn)	600 (60)	700 (70)	770 (77)	900 (90)
Maximum operating temperature, °C			100	
Connecting threads <sup>2</sup> , - top and bottom according to TR 14-157-61-99	TMK-3 102	TMK-3 114	TMK-3 120	TMK-3 140

<sup>1</sup> Calculated value.

<sup>2</sup> Reference only, depends on operating conditions of general mechanical rubber goods in a well.

<sup>3</sup> Connecting thread type is agreed with the Customer.

DMG MORI

ecoTurn 450



The control panel is a vertical, white and black unit. At the top is a color LCD screen displaying a software interface with various data fields and graphs. Below the screen is a numeric keypad with black buttons and a few colored function keys (red, green, yellow). Further down is a larger keypad with many small, light-colored buttons, some of which are also colored. There are also several rotary dials and a large red emergency stop button.



A standard black computer keyboard is mounted on a white tray that is part of the control panel's structure.





## Seat-trap SL

Seat-Trap is applied for accumulation of cementing plugs and seats fragments and to facilitate their following drilling out.

Seat-trap inner parts are made of aluminium alloy.

PARAMETER DESCRIPTION	VALUE		
	SL.102	SL.114	SL.178
Casing string nominal diameter RIH with the device, mm	102	114	178
Maximum outer diameter of the device, mm	110	127	187
Drift diameter of the device, after drilling, mm	89	99	157
Drift diameter of the device, before drilling, mm	21	28	50
Maximum internal pressure on the body, MPa	70		
Length of the device fully assembled, mm	385	420	450
Device weight, kg, not more	7,3	12,3	27
Maximum tensile force <sup>1</sup> , kN (tn)	600 (60)	700 (70)	1200 (120)
Connecting threads <sup>2</sup> , - top and bottom according to GOST 632-80	OTTM102	OTTM114	OTTM178

<sup>1</sup> Calculated value.

<sup>2</sup> For SL 102 the connecting thread is made according to TR 14-161-163-96.



## Auxiliary top modular packer PDV-M

PDV-M device is applied for hermetic connection with a liner "head" run in with the help of hangers PHCZ-type and for additional sealing of a liner "head".

Besides, the device joint shoe can be used to ensure sealed joint with a liner "head" and if required to build up a liner to fix the leaks above the liner "head".

The device is RIH on drill pipes and is actuated by the partial tool weight unload. The disconnection is performed automatically at under tension over own weight more than 5 tn

PARAMETER DESCRIPTION	VALUE		
	PDV-M.102	PDV-M.114	PDV-M.127
Liner nominal diameter equipped with the device, mm	102	114	127
Maximum outer diameter of the device, mm	122	140	149
Drift diameter of the device, mm	89	99	111
Minimum load for the packer actuation, kg	5000		
Maximum tension for disconnection, kg	5000		
Maximum tensile force <sup>1</sup> , kN	600	700	800
Maximum pressure differential between the zones isolated by a hydro-mechanical packer, $\Delta P$ , MPa	15		
Length of the device fully assembled, mm	1430	1485	1720
Device weight, kg, not more	37,4	64	77,4
Maximum operating temperature <sup>2</sup> , C°	100		
Connecting threads:			
- top according to GOST 28487-90	Z-86	Z-102	Z-102
- bottom according to TU 14-161-163	OTTM 102	OTTM 114	OTTM 127

<sup>1</sup> Calculated value when stresses reach yield point of the material.

<sup>2</sup> Reference only, depends on operating conditions of general mechanical rubber goods in a well.



## Top auxiliary packer PDV-2

PDV-2 device is applied for hermetic connection with a liner "head" run in with the help of hangers PHCZ-type and for additional sealing of a liner "head".

The device is RIH on drill pipes and is actuated with the partial drilling string weight unload. The disconnection is performed automatically by a drill string pulling out.

PARAMETER DESCRIPTION	VALUE	
	PDV2.102/146	PDV2.114/168
Liner nominal diameter equipped with the device, mm	102	114
Maximum outer diameter of the device, mm	122	140
Drift diameter of the device, mm	89	99
Minimum load for the packer actuation, kg	5000	
Maximum tension for disconnection, kg	5000	
Maximum tensile force <sup>1</sup> , kN	600	600
Maximum pressure differential between the zones isolated by a hydro-mechanical packer, $\Delta P$ , MPa	15	15
Length of the device fully assembled, mm	1724	1920
Device weight, kg, not more	62	95
Maximum operating temperature <sup>2</sup> , °C	100	
Connecting threads:		
- top according to GOST 28487-90	Z-86	Z-102

<sup>1</sup> Calculated value when stresses reach yield point of the material.

<sup>2</sup> Reference only, depends on operating conditions of general mechanical rubber goods in a well.

PARAMETER DESCRIPTION	VALUE	
	PDV2.127/178	PDV2.168/245
Liner nominal diameter equipped with the device, mm	127	168
Maximum outer diameter of the device, mm	152	213
Drift diameter of the device, mm	111	158,5
Minimum load for the packer actuation, kg	5000	
Maximum tension for disconnection, kg	5000	
Maximum tensile force <sup>1</sup> , kN	800	1000
Maximum pressure differential between the zones isolated by a hydro-mechanical packer, $\Delta P$ , MPa	15	70
Length of the device fully assembled, mm	2407	2540
Device weight, kg, not more	112,3	216,1
Maximum operating temperature <sup>2</sup> , °C	100	
Connecting threads:		
- top according to GOST 28487-90	Z-102	Z-133

<sup>1</sup> Calculated value when stresses reach yield point of the material.

<sup>2</sup> Reference only, depends on operating conditions of general mechanical rubber goods in a well.



## Trip stop-tap SPD2

SPD2 device is applied for the liner and transport string self-priming in the process of running into a well and receiving the "bump" signal while performing direct cementing during which the hollow cementing plug, as a part of PHCZ or PHGMC liner hanger, together with the upper cementing PCV plug is set into the device seat.

Besides, the device can be applied for actuation of PHRC hanger anchor unit while RIH of a liner with continuous cementing using PHRC hanger.

PARAMETER DESCRIPTION	VALUE		
	SPD2.102	SPD2.114	SPD2.127
Liner nominal diameter equipped with the device, mm	102	114	127
Maximum outer diameter of the device, mm	114	127	141,3
Drift diameter of the device, mm	88	99	111
Bush shear pressure, MPa± 10%	6,0		
Seat shear pressure, MPa± 10%	18,0		
Maximum tensile force <sup>1</sup> , kN	600	700	800
Length of the device fully assembled, mm	721	743	781
Device weight, kg	19,2	24,7	27,6
Maximum operating temperature <sup>2</sup> , C°	100		
Connecting threads according to GOST 632-80 (for SPD2.102 according to TR 14-161-163-96)	OTTM-102	OTTM-114	OTTM-127

<sup>1</sup> Calculated value when stresses reach yield point of the material.

<sup>2</sup> Reference only, depends on operating conditions of general mechanical rubber goods in a well.







## Bow-spring centralizer

### PC

PC-type Bow-Spring welded Centralizers are applied for casing strings centering during their RIH and cementing inside wells. The use of centralizers allows to achieve uniform clearance between a casing pipe and well walls, thus preventing appearance of behind-the-casing cross flows (total insulation with cement slurry, without breaks), and as a result significantly extending the well service life. Centering of a casing string is provided with preset bow spring properties of centralizer planks.

PC-type bow-spring centralizers consist of two shells and six bow springs with a specific profile and section.

The principal innovation in operation is in the design of PC-type bow-spring centralizer. PC-type bow spring welded centralizers are provided with only two minimally loaded weld seams arranged on centralizer shells. Centering planks of the centralizer have no welds and are made of a solid steel sheet.

PC-type bow-spring centralizers are made of high quality sheet steel using sheet cutting method and further multistage treatment of the blanks on sheet-benders.

Automatic sheet cutting provides perfect blanks with no need in further mechanical treatment. Multistage bending on sheet-benders provides high strength and precision of the constructions. Final welding and thermal treatment provide uniform strength of the centralizer's structure.

PC-type bow-spring centralizers are fixed on a casing string with special fixing screws.

CODE	VALUE							
	Casing string diameter, mm	Outer diameter, mm	Well bore diameter, mm	Inner diameter, mm	Radial centering force, kg	Axial force pushing centralizer into a nominal diameter, kg	Centralizer length, mm	Weight, kg, not more
PC.89/120-124	89	145	120 – 124	92	800	150	396	1,97
PC.102/122	102	145	120 – 124	106	800	185	396	1,9
PC2A.114/144	114	160	140 – 143	116	800	190	620	4,95
PC2B.114/144	114	148	140 – 143	116	800	190	620	5,68
PC.127/156	127	170	157	130	800	260	620	4,6
PC.140/191-216	140	269	191 – 216	142	800	305	620	6,2
PC.140/191-216-01	140	254		142	800	280	680	6,1
PC.146/191-216	146	274		148	800	320	680	6,5
PC.146/191-216-01	146	255		148	800	300	680	6,52
PC.168/216	168	295,5	216	171	800	430	680	7,2
PC.168/216-01	168	254		171	800	400	680	7,2
PC.178/216	178	297,5		181	800	465	680	8,4
PC.178/216-01	178	256		181	800	400	680	8,3
PC.178/216-02	178	244		181	800	400	680	7,2
PC.219/295	219	350	295	222	1050	565	680	8,5
PC.245/295	245	373,5		249	1050	635	680	8,9
PC.245/295-01	245	352		249	1050	600	680	9
PC.324/394	324	448	394	329	1350	900	680	13,3



## Hard elastic centralizer

### PCR

PCR-type Bow-Spring welded Centralizers are applied for casing strings centering during their RIH and cementing inside wells. Centering of a casing string is provided with preset bow spring properties of centralizer planks. PCR-type bow-spring centralizers consist of two shells and 6 bow springs with a specific profile and section.

The principal difference of PCR centralizers from PC centralizers is a plank radially curved inward and the outer diameter. PCR centralizer outer diameter is less for some millimeters than well bore diameter which it is run in.

The technical result is achieved through the construction of PCR bow-spring centralizer. It consists of centering arch planks and two solid shells, the centralizer arch spring planks have a radial shape in section. This prevents cutting of casing inner surface with centralizer sharp planks edges and wall layer destruction in open well bore. As the result, casing passing through a well bore becomes easier, especially in low-angle and horizontal parts as centralizer arch planks interact with casing and well bore inner surface through sliding friction with the lowest friction coefficient.

EXTERNAL CASING ATTACHMENTS

PARAMETER DESCRIPTION	VALUE										
	PCR.102/124	PCR.102/143	PCR.114/143	PCR.114/146	PCR.114/152	PCR.114/156	PCR.168/216	PCR.168/221	PCR.178/216	PCR.178/221	PCR.245/295
CSG diameter (mm)	102	102	114	114	114	114	168	168	178	178	245
OD (mm)	124	143	143	146	152	156	216	221	216	221	295
Wellbore Diameter (mm)	123,8	142,9	142,9	146	152,4	155,6	215,9	220,7	215,9	220,7	295,3
ID (mm)	104	104	116	116	116	116	170	170	180	180	248
Radial Centralizing Force at Eccentricity of 67% kg	209	210	211	206	224	235	1332	1019	1300	1029	1140
Centralizer length (mm)	400	400	315	315	315	315	330	330	330	330	400
Tool Weight (kg) not more than	2,3	2,3	2,8	2,9	2,8	2,4	3,9	3,9	4,3	4,3	6,4



## Low-frictional turbulence generating centralizer

### CTN

Low-frictional Turbulence Generating Centralizer is applied for casing RIH and turbulence generation of cement slurry upward flow during cementing. Low-frictional centralizers application allows to improve casing passing through a bore, especially in horizontal wells and wells with significant vertical deviation.

CTN centralizers reduce the risk of tool sticking. They are mounted on a casing pipe movably and are protected from shifting with lockdown rings FK.

PARAMETER DESCRIPTION	VALUE						
	CTN.102/116	CTN.102/119	CTN.114/138	CTN.114/150	CTN.127/146	CTN.168/206	CTN.178/206
Liner nominal diameter equipped with the device, mm	102	102	114	114	127	168	178
Outer diameter, mm	116	119	138	150	146	206	206
Nominal open hole diameter (bit diameter) where the device is RIH, mm	123,8	123,8	142,9	155,6	155,6	215,9	215,9
Length, mm	185	185	220	220	220	250	250
Friction coefficient at dry friction	0,2						
Friction coefficient at fluid friction	less than 0,08						

It can be produced according to Customer's individual sizes.



## Stop ring SKC

Stop Ring SKC is applied to hold centralizers at the required part of a casing string during its running in and cementing in a hole.

The ring is fixed at the required part of a casing pipe with special fixing screws.

PARAMETER DESCRIPTION	VALUE					
	SKC.102	SKC.114	SKC.127	SKC.146	SKC.168	SKC.178
Casing string nominal diameter equipped with stop rings SKC, mm	102	114	127	146	168	178
Maximum outer diameter, mm	114,3	127,0	139,7	165	188	193,7
Inner diameter of the device, mm	104	116	129	150,5	172	181
Width of the ring, mm, not more	30					
Number of fixing screws, pcs	4			6		
Device weight, kg, not more	0,25	0,31	0,32	0,72	0,90	0,74

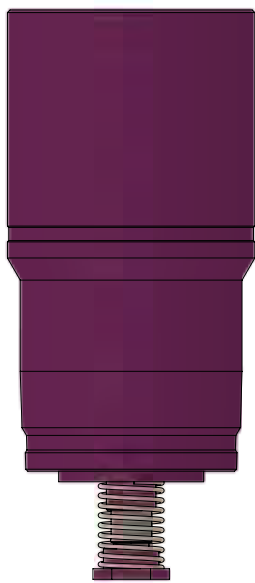

## Cementing throttle check valve **CKOD**

Cementing Throttle Check Valve is applied for prevention of cement slurry backflow during cementing and for self-priming of casing inner space during RIH.

Inner parts of the valve are made of easily drilled out materials.

PARAMETER DESCRIPTION	VALUE				
Casing string nominal diameter RIH with CKOD valve, mm	146	168	178	245	324
Maximum outer diameter, mm	166	187	194,5	270	348
Drift diameter, mm	130,7	152,3	161,6	226,7	304,9
Ball diameter, mm	76				
Length in operating position, mm	430	432	436	429	442
Length in transport position, mm	420	430	440	440	450
Weight in operating position, kg	19,5	22,1	24,5	55,1	95,9
Weight in transport position, kg	20,4	23,2	25,7	56,4	98,3
Maximum operating temperature <sup>1</sup> , °C	100				
Maximum tensile force on the device body <sup>1</sup> , kN (tn)	900 (90)	920 (92)	1050 (105)	1700 (170)	1900 (190)
Maximum internal overpressure on the valve body, MPa	25				
Maximum differential pressure maintained by the valve, MPa	15				
Connecting threads <sup>3</sup> :	OTTM	OTTM	OTTM	OTTM	OTTM
- top and bottom according to GOST 632-80	146	168	178	245	324

<sup>1</sup> Reference only, depends on operating conditions of general mechanical rubber goods in a well.

<sup>2</sup> Calculated value when stresses reach yield point of the material.

<sup>3</sup> OTTG or BTS connecting threads can be produced on Customer's demand.



## Casing shoe

### BK

BK is a casing shoe applied for directing a casing string during its running in the well bore.

There are 4 options of design:

1. BK-M are shoes with metal cap (if the customer approves, a cap is made of aluminium alloy according to D16T GOST 4784-97 or of cast iron mark Sch20 GOST 1412-85, default variant is aluminium);
2. BK-M are shoes with metal cap "bullet-shaped" (a cap is made of aluminium alloy according to D16T GOST 4784-97);
3. BK-P are shoes with polymer cap. BK-P shoes can also be produced without wash ports ("blind"). Index "G" is added to such models.
4. BK-Vr are rotating shoes with rotating eccentric cap (a cap is made of aluminium alloy according to D16T GOST 4784-97).



## Shoes with polymer-concrete cap

CODE	VALUE							
	Casing string nominal diameter, mm	Central hole diameter, mm	Side holes diameter, mm	Drift diameter, mm	Connecting threads <sup>1</sup> , according to GOST 632-80	Outer diameter, mm, not more	Length, mm	Weight, kg, not more
BK-P 89	89	40	10	80	89	108	262	7,4
BK-P 102	102	40	12	91	OTTM 102	110	260	5,7
BK-P 114	114	50	12	102	OTTM 114	127	287	8,1
BK-P 127	127	60	12	115	OTTM 127	141,3	285	9,9
BK-P 140	140	70	15	127	OTTM 140	153,7	294	15,4
BK-P 146	146	70	15	133	OTTM 146	166	302	15,5
BK-P 168	168	80	15	155	OTTM 168	187,7	316	18,6
BK-P 178	178	90	18	164	OTTM 178	194,5	341	19,6
BK-P 194	194	100	20	178	OTTM 194	216	365	28,1
BK-P 219	219	110	20	205	OTTM 219	245	370	35,8
BK-P 245	245	120	20	228	OTTM 245	270	390	43,1
BK-P 273	273	130	20	259	OTTM 273	298,5	384	56,6
BK-P 299	299	150	20	281	OTTM 299	324	389	63,4
BK-P 324	324	160	20	307	OTTM 324	351	400	62,6
BK-P 340	340	170	20	323	OTTM 340	365	405	63,6
BK-P 426	426	220	20	406	OTTM 426	451	433	123,5

<sup>1</sup> Connecting thread type is agreed with the Customer. For BK-P 89, BK-P 89G the thread is produced according to GOST 633-80; for the shoe BK-P 102, BK-P 102G, BK-M 102 the thread is produced according to TU 14-161-163-96.

## Shoes with metal cap

CODE	VALUE							
	Casing string nominal diameter, mm	Central hole diameter, mm	Side holes diameter, mm	Drift diameter, mm	Connecting threads <sup>1</sup> , according to GOST 632-80	Outer diameter, mm, not more	Length, mm	Weight, kg, not more
BK-M 89	89	45	10	82	89	108	198	5,2
BK-M 102	102	50	12	94	OTTM 102	110	218	4
BK-M 114	114	55	15	107	OTTM 114	127	259	7,1
BK-M 127	127	60	15	119	OTTM 127	141,3	269	8,2
BK-M 140	140	70	15	132	OTTM 140	153,7	263	9,7
BK-M 146	146	70	15	138	OTTM 146	166	268	12,5
BK-M 168	168	80	15	160	OTTM 168	187,7	282	15,9
BK-M 178	178	90	20	170	OTTM 178	194,5	293	16,5
BK-M 194	194	100	20	185	OTTM 194	216	308	22,9
BK-M 219	219	110	20	210	OTTM 219	245	328	31,4
BK-M 245	245	120	20	236	OTTM 245	270	341	36,8
BK-M 273	273	130	20	264	OTTM 273	298,5	350	43,6
BK-M 299	299	150	20	290	OTTM 299	324	352	47,8
BK-M 324	324	160	20	315	OTTM 324	351	359	56,4
BK-M 340	340	170	20	331	OTTM 340	365	364	58,4
BK-M 426	426	220	20	415	OTTM 426	451	406	89,7

<sup>1</sup> Connecting thread type is agreed with the Customer. For BK-M 89, BK-M 89G the thread is produced according to GOST 633-80; for the shoe BK-M 102, BK-M 102G the thread is produced according to TU 14-161-163-96; for the shoe BK-M 426 the thread is produced according to TU 14-3-760-78.

## Bullet-shaped shoes

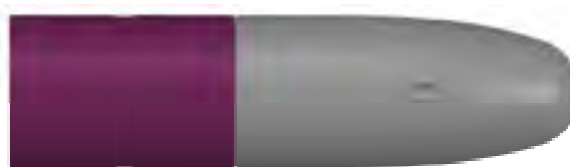

CODE	VALUE							
	Casing string nominal diameter, mm	Central hole diameter, mm	Side holes diameter, mm	Drift diameter, mm	Connecting threads <sup>1</sup> , according to GOST 632-80	Outer diameter, mm, not more	Length, mm	Weight, kg, not more
BK-M 102P	102	35	15	94	OTTM 102	110	450	7,8
BK-M 114P	114	35	15	107	OTTM 114	127	465	11

<sup>1</sup> Connecting thread type is agreed with the Customer. For BK-M 102P the thread is produced according to TU 14-161-163-96.

## Shoes with rotating eccentric cap



CODE	VALUE						
	Casing string nominal diameter, mm	Central hole diameter, mm	Drift diameter after drilling, mm	Connecting threads <sup>1</sup> , according to GOST 632-80	Outer diameter, mm, not more	Length, mm	Weight, kg, not bore
BK-Vr 102	102	45	88	OTTM 102	110	273	5,7
BK-Vr 114	114	50	99	OTTM 114	127	333	9,4
BK-Vr 127	127	60	117	OTTM 127	141,3	347	11,4
BK-Vr 168	168	65	155	OTTM 168	188	427	22,1

# Well screen

## FS, FB

Well screens design made by Research and Development Center "ZERS" LLC is based on survey of a great amount of research works carried out by Russian and foreign researchers, as well as on results of long-time field experience of using such devices and recommendations of oil and gas production enterprises.

There are 2 types of well imperfection such as penetration degree imperfection and opening attitude imperfection.

A well imperfect according to the penetration degree is a well with an open hole but it didn't enter formation at full capacity, only partially (fig. 1a). A well though brought to formation bottom but connected with formation only through holes in casing pipes, a cementing ring or a special well filter is called imperfect according to formation penetration (fig. 1b). In practice these wells occur the most frequently.

Rate  $G$  of an imperfect well is most frequently lower that rate  $G_c$  of a perfect well, working in the same conditions than this imperfect one.

EXTERNAL CASING ATTACHMENTS

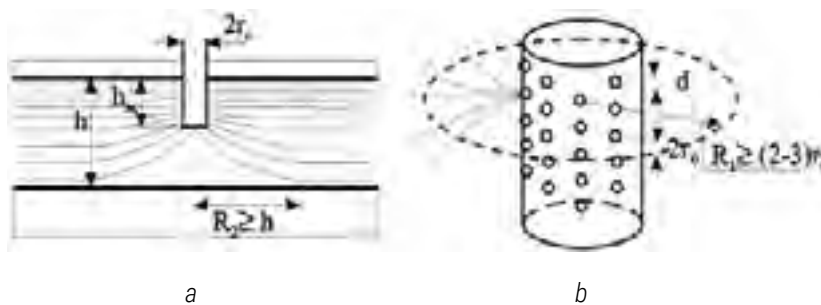

Fig. 1. Fluid inflow chart to an imperfect well:

- a* – penetration degree;
- b* – formation opening.

It should be noted that imperfectness of a vertical well influences less significantly on its productivity that imperfectness of a horizontal well.

Research performed by V.I. Schurov through electrolytic modelling (fig. 2) revealed significant dependence of the rate from density of perforations only up to 16-20 holes for 1 m. Further increase of a number of holes in filter case doesn't increase the rate but leads to causeless increase of economic costs.

It should be noted that well productivity penetrating anisotropic formation with less holes diameter and a bigger holes number exceeds productivity gained from larger holes diameter but less holes number (fig. 4.3, curve 2, 3, 4).

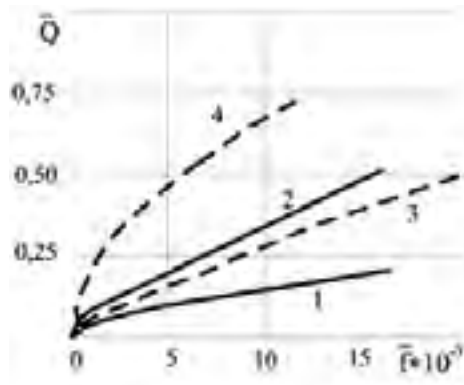

Fig. 4.3  $\bar{Q}$  dependence of  $\bar{f}$  perforation porosity  
 1 – anisotropic formation ( $d=6.3 \cdot 10^{-3}m$ );  
 2 – isotropic formation ( $d=6.3 \cdot 10^{-3}m$ );  
 3 – isotropic formation ( $d=2 \cdot 10^{-3}m$ );  
 4 – isotropic formation ( $d=0.5 \cdot 10^{-3}m$ );  
 $d$  – perforation holes diameter;  $\bar{f}=f_h/F$ ;  $f_h$  – holes surface  
 for 1 lin. m of perforated surface  $F$

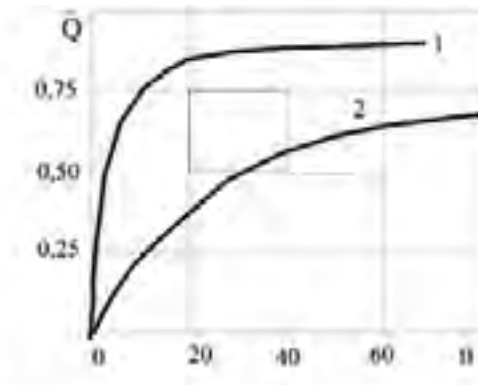
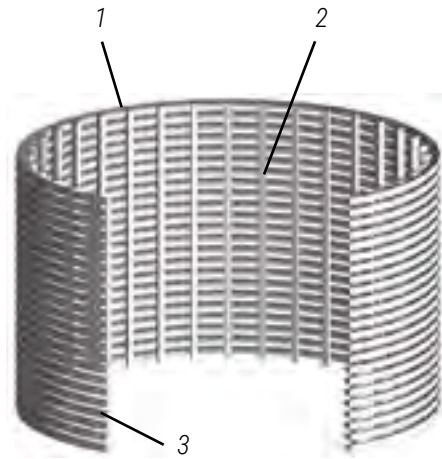

Fig. 4.4  $Q$  dependence of the number of holes  $n$   
 1 –  $a=0.3$ ,  $b=0.1$ ;  
 2 –  $a=10$ ,  $b=0.001$

*Without further reasons and calculations we should notice that LLC RDC "ZERS" considers the most efficient well filter design including 28 holes with diameter 10 mm per 1 m.*

FS-type well filter is applied as a part of a casing string filtering part and is used to prevent destruction of productive formation bottom-hole area and sand or other mechanical impurities intrusion. The filter is run into productive formation and installed in a required interval of the well with the help of a liner hanger or as a part of a casing string. FS-type filter is a device consisting of a case with holes on the outer side of which there is a slit-type filter element manufactured by spiral winding of stainless steel wire with a special triangular section onto longitudinal load-bearing elements (stringers). The length of the filter element, the gap size and a number of holes in the body as per 1 linear meter of its length are defined by its intended operational conditions and are subject to approval with the customer.

FS filter is available in variants with hollow plugs "caps" (variant K) and without them. The plugs are installed in the holes of the case and provide filter leak tightness up to 15 MPa of internal overpressure. It thus allows to washover a well through a casing shoe. The hollow plugs are removed by mechanical destruction.



- 1 - Shaped wire.
- 2 - Stringer.
- 3 - Gap width (clearance).

FB-type wireless filter differs from FS filter by lack of filter element on the case outer surface. It is also available with hollow plugs "caps" and in plug-less variants. Maximum test pressure of a filter for the variant with hollow plugs is 15 MPa.

Here is an example of identification symbols to order a well screen with hollow plugs for a casing string with diameter 114 mm with slit clearance size of 0,25 mm and filter element length of 3000 mm provided with a positive centralizer with diameter of 136 mm:

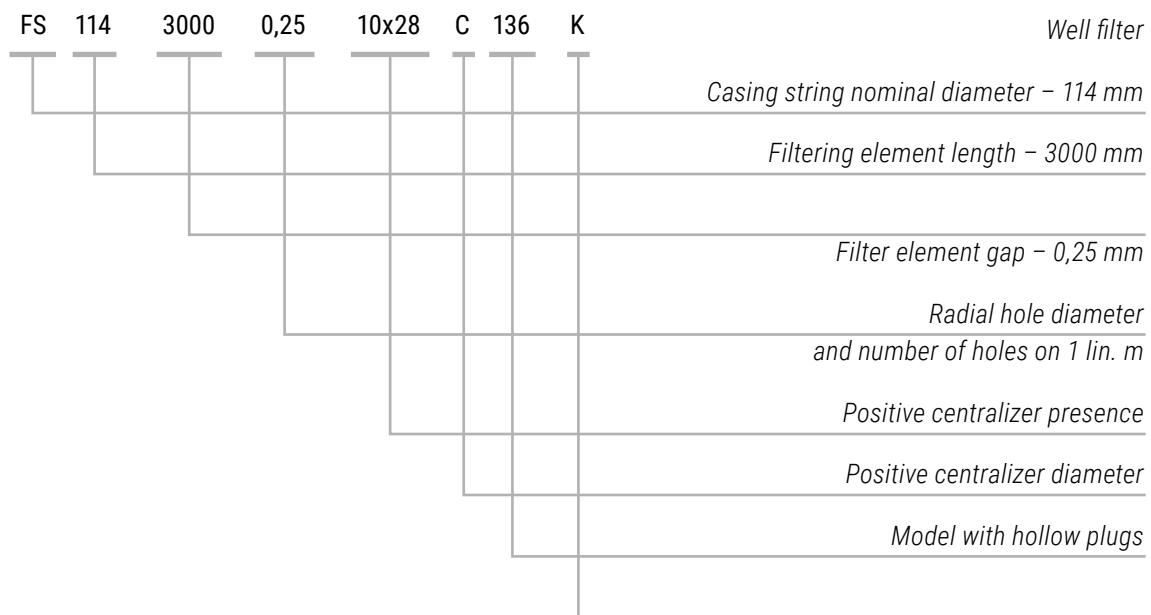

Here is an example of identification symbols to order a wireless filter with hollow plugs with holes diameter 12 mm for a casing string with diameter 102 mm:

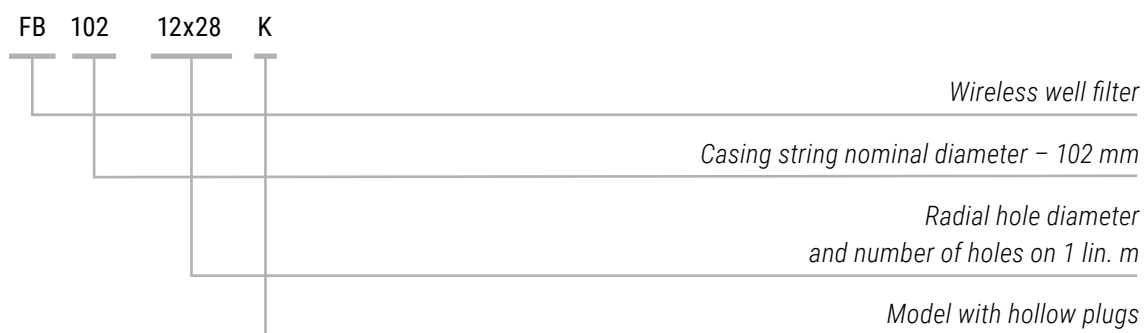

The figure shows an **FS**-type filter designed with hollow plugs.

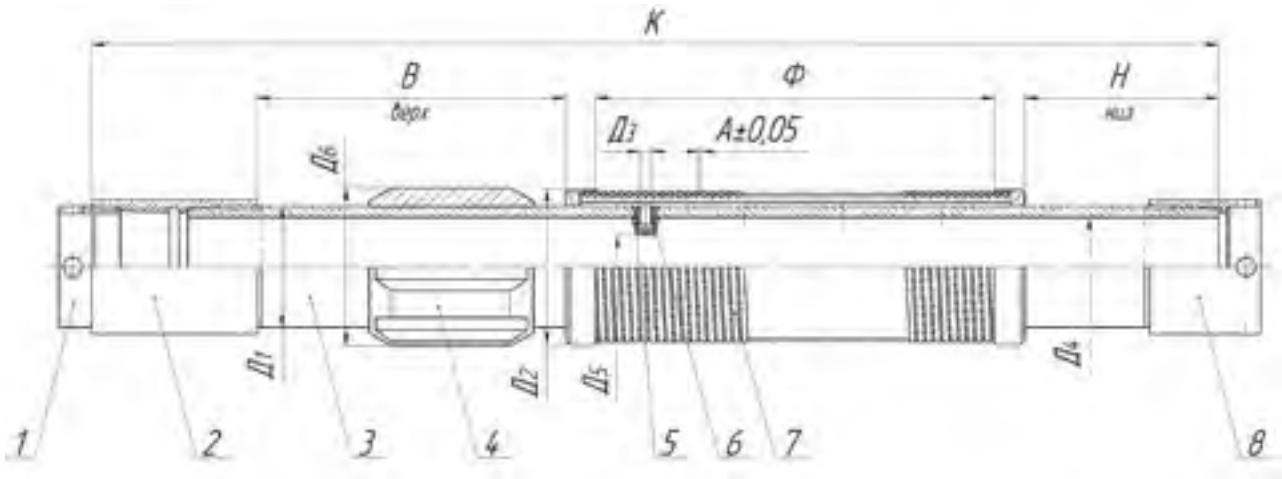

1. Plug 2. Collar 3. Body 4. Solid centralizer 5. Hollow plug 6. Hub 7. Filtering element 8. Plug

EXTERNAL CASING ATTACHMENTS

PARAMETER DESCRIPTION	VALUE						
Casing string diameter, D1, mm	48	60	73	89	102	114	127
Maximum filter element diameter, D2, mm	65	78	90	107	116	129	148
Radial holes diameter in model with hollow plugs, D3, mm	10						
Radial holes diameter in model without hollow plugs, D3*, mm	12; 15						
Filter drift diameter, D4, mm	40,3	50,3	62,0	75,9	88,6	101,5	114,2
Outer diameter according to positive centralizer, D5*, mm	-	-	100	116	125	136	150
Filter length, K*, mm	4588...11088			4600...11100			
Filter element length, F*, mm	3000 or 6000						
Top part length of filter body, V, mm	not less than 1200						
Bottom part length of filter body, N, mm	no less than 300						
Filter element gap, A±0,05*, mm	0,15; 0,20; 0,25; 0,30; 0,35; 0,40; 0,50; 0,60; 0,70; 0,85; 1,00						

\* Other sizes are available on Customer's demand.



The figure shows an **FB**-type filter designed with hollow plugs.

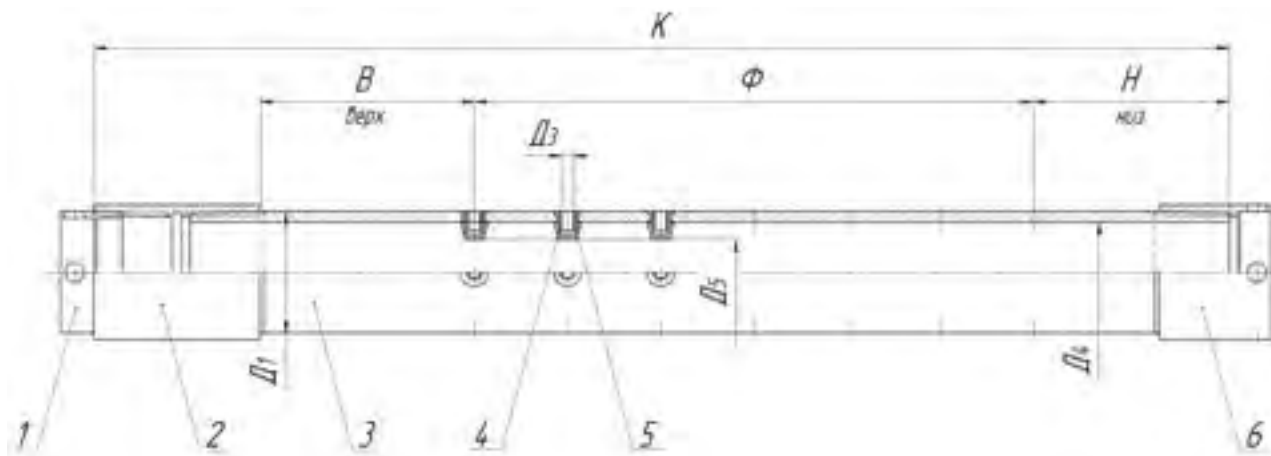

1. Plug 2. Collar 3. Body 4. Hollow plug 5. Hub 6. Plug 7. Plug

PARAMETER DESCRIPTION	VALUE							
Casing string diameter, D1, mm	140	146	168	178	194	219	245	
Maximum filter element diameter, D2, mm	159	166	188	198	213	238	264	
Radial holes diameter in model with hollow plugs, D3, mm	10							
Radial holes diameter in model without hollow plugs, D3*, mm	12; 15							
Filter drift diameter, D4, mm	127,3	133,1	153,7	164,0	178,5	205,7	228,7	
Outer diameter according to positive centralizer, D5, mm	162	174	195	206	224	258	285	
Filter length, K*, mm	4616...11134							
Filter element length, F*, mm	3000 or 6000							
Top part length of filter body, V, mm	not less than 1200							
Bottom part length of filter body, N, mm	no less than 300							
Filter element gap, A±0,05*, mm	0,15; 0,20; 0,25; 0,30; 0,35; 0,40; 0,50; 0,60; 0,70; 0,85; 1,00							

\* Other sizes are available on Customer's demand.



# DRILLING EQUIPMENT

Selective Washing Device  
for Wells

**USPS**

**114**

DRILLING  
EQUIPMENT



## Selective washing device for wells

### USPS

Selective Washing Device for Wells is applied for performing injections of plugs with fillers during drilling with bottomhole engine. The device is mounted above BHA.

When the device is not actuated, drilling mud goes through it smoothly. To activate the device it is necessary to drop an activation ball into drilling pipes and pump until it is set into a seat. When the activation ball reaches the seat, circulating ports open. Due to this BHA is hermetically disconnected as it is mounted lower. The circulation goes through the side ports and the bridging material is pumped into loss zones. When a drilling pump is stopped, a spring returns the stem to the top position and circulation ports are closed.

After all the planned technical operations two steel deactivation balls are dropped into drilling pipes and pumped with calculated volume of drilling mud in order to deactivate the device. Deactivation balls reach the device and close the ports due to liquid flow and the deactivation ball is pumped through a seat. The circulating ports are closed. Drilling mud continues to flow below the device. Used balls both activation and deactivation one come to a trap and don't interfere with the following operations.



PARAMETER DESCRIPTION	VALUE	
	USPS.121	USPS.171
Outer diameter of the device, mm	121	171
Diameter of circulating ports, mm	28	28
Number of circulating ports, pcs	2	2
Number of operation cycles, without pulling out, units	5	5
Activation ball diameter, mm	38,1	50,8
Deactivation ball diameter, mm	34,9	34,9
Length, mm	1688	1841
Weight, kg	113	260
Connecting threads according to GOST 632-80 (for SPD2.102 according to TU 14-161-163-96)	Z-102	Z-133
Maximum tensile force <sup>1</sup> , kN (tn)	1962 (200)	4905 (500)

<sup>1</sup> Calculated value.



# HYDRAULIC FRACTURING

Technical Equipment Set  
for a Liner Well Casing with  
the following Multistage  
Hydraulic Fracturing

**120**

Hydraulic Packer  
for Hydraulic Fracturing

**PGRP**

**122**

Water and Oil Swellable  
Packer for Hydraulic  
Fracturing

**124**

Closing Frac Port  
**FPZ** and **FPZN**

**126**

Dissolvable  
balls

**128**

Pusting frac port

**FPR**

**129**

Composite  
bridge plug  
**MPR**

**130**

Collar for Collar  
Cementing Sleeve for  
Hydraulic Fracturing

**MMC-G**

**132**

Collar  
control tong

**KUM.114**

**134**

Collar for Staged  
Hydraulic Fracturing  
with an Operating Device

**MSGRP-U**

**135**



## Technical equipment set for a liner well casing with the following multistage hydraulic fracturing

Technical equipment sets for multistage hydraulic fracturing vary in a liner well casing type:

- without cementing;
- with collar cementing;
- with continuous cementing.

There are also different types of horizontal sector zonal isolation:

- with the help of swellable packers;
- with the help of hydro-mechanical packers.

A set for well casing with a liner without cementing with the following multistage hydraulic fracturing includes the following technical equipment:

1. Shoe;
2. Ball check valve KOSH2;
3. Frac port FPZN
4. Required amount of packers (swellable or hydro-mechanical) and cfrac ports FPZ which are opened with balls;
5. Noncemented liner hanger PHN.

A set for well casing with a liner with cementing with the following multistage hydraulic fracturing includes the following technical equipment:

1. Shoe;
2. Ball check valve KOSH2;
3. Frac port FPZN;
4. Required amount of packers (swellable or hydro-mechanical) and frac ports FPZ which are opened with balls;
5. Seat-trap SL;
6. Collar cementing packer PGMC or collar for collar cementing for hydraulic fracturing MMC-G;
7. Cemented liner hanger PHRC or PHCZ or PHGMC.

After well casing with a liner and normalization are finished, the connection with a liner is performed with a hydraulic fracturing device UGRH, wellhead set-up and frac fitting are mounted.



Actually multistage hydraulic fracturing is performed with frac ports FPZ which are actuated one by one at the right time. Collars are opened with internal overpressure build-up in a pass by pumping pressing balls of different diameter beginning with the smallest one and their setting to seats with different drift diameter. FPZN hydraulically opening collar is used for the first interval hydraulic fracturing. Zonal isolation in outer annular space is performed with hydro-mechanical and swellable packers included into assembly RIH.

Equipment sets are delivered for liners 102 and 114 mm and can be used for up to 10 intervals of hydraulic fracturing at operational pressure up to 70 MPa.



## Hydraulic packer for hydraulic fracturing **PGRP**

Hydraulic Packer PGRP is applied for open wellbore (or casing string) zonal isolation during different technological operations performance, including multistage hydraulic fracturing (MSHF).

The packer operates as follows:

- after liner running into the adjusted depth and flushing, a controlling ball is dropped till its setting into a valve KO seat, after which the pressure starts to increase.
- for packer hydraulic drive unit actuation the overpressure 16 (33) MPa is created in liner pipes. When the adjusted pressure is achieved, shear bolts are cut off and the packer is actuated.

For packer operation at significant pressures it is recommended to install the packer in intervals with open bore nominal diameter.

PARAMETER DESCRIPTION	VALUE				
	PGRP.102/118	PGRP.102/136	PGRP.114/136	PGRP.114/144	PGRP.114/148
Liner nominal diameter equipped with the device, mm	102	102	114	114	114
Open borehole nominal diameter (bit diameter) which the device is run in, mm	123,8	142,9	142,9	152,4	155,6
Outer diameter, mm	118	136	136	144	148
Drift diameter, after actuation, mm	88	88	99	99	98
Maximum tensile axial force on the body <sup>1</sup> , kN	600	600	700	700	700
Internal overpressure for packer actuation, MPa	16				
Maximum pressure differential between the zones isolated by the packer, MPa	70				
Maximum internal overpressure on the packer, MPa	70				
Maximum operating temperature <sup>2</sup> , °C	100				
Length, mm	1460	1295	1610	1700	1700
Weight, kg	51	56	65	78	80
Connecting threads: - top and bottom according to GOST 632-80 (for PGRP.102/118 and PGRP.102/136 according to TU 14-161-163-96)	OTTM-102	OTTM-102	OTTM-114	OTTM-114	OTTM-114

<sup>1</sup> Calculated value.

<sup>2</sup> Reference only, depends on operating conditions of general mechanical rubber goods in a well.

## Water and oil swellable packer for hydraulic fracturing

RDC "ZERS" LLC has developed and produced oil swellable packers in which the sealing element is made of elastomeric material that is able to swell out at the contact with oil and can hold the pressure differential of 700 atm in a nominal diameter bore.

Besides, these packers' body is made of steel with improved strength properties.



PARAMETER DESCRIPTION	PNV AND PNN PACKER TYPICAL SIZE					
	102/118	102/124	114/136	114/144	114/148	127/148
Liner nominal diameter on which the packer is RIH, mm	102	102	114	114	114	127
Recommended wellbore diameter which the packer is installed in, mm	124	132	143	152	156	156
	...		...	...	...	...
	128		146	156	160	160
Maximum pressure differential on the packer, MPa	70					
Elastomeric material length, mm	1200					
Packer length, mm	2600					
Packer outer diameter, mm	118	124	136	144	148	148
Weight, kg	58	61	72	75	78	81
Maximum operating temperature, °C	100					
Estimated packer swelling time till overall wellbore space isolation <sup>1</sup> , days	5...7			7...9		

<sup>1</sup> Parameters values are shown for the rated hole diameter on the base of used swelling resins types and well conditions (temperature, well fluid type on running in and operation, etc.).



## Closing frac port FPZ and FPZN

Closing Frac Port FPZ is applied for multistage hydraulic fracturing.

A set of frac ports is RIH as a part of a liner GRP assembly. Each port is installed into required wellbore zone. Frac ports FPZN is installed in the first hydraulic fracturing zone (above the shoe, check valves).

FPZN frac port is actuated with pressure build-up to 30 MPa.

FPZ frac ports are actuated through dropping and pumping of balls with different diameter into a well beginning with the smallest one.

Frac ports are run in as a part of a liner together with swellable and hydro-mechanical packers;

The outstanding feature of FPZ and FPZN frac ports is a possibility of closing them after seats drilling out for balls. Closing is done by a collar control tong conveyed on tubing or coiled tubing KUM.114./by.

Collars can be equipped both with usual metallic balls and balls of soluble composite material.

NUMBER	BALLS DIAMETER		COLLAR CODE
	mm	inches	
1	70,92	2,792	FPZ*/70 <sup>1</sup>
2	67,57	2,660	FPZ*/67
3	64,32	2,532	FPZ*/64
4	61,19	2,409	FPZ*/61
5	58,17	2,290	FPZ*/58
6	55,25	2,175	FPZ*/55
7	52,43	2,064	FPZ*/52
8	49,71	1,957	FPZ*/49
9	47,07	1,853	FPZ*/47

<sup>1</sup> \* means collar diameter.

HYDRAULIC  
FRACTURING

PARAMETER DESCRIPTION	VALUE	
	FPZN.114	FPZ.114
Liner nominal diameter equipped with the device, mm	114	114
Open borehole nominal diameter (bit diameter) which the device is run in, mm	142,9	142,9
Outer diameter, mm	137	137
Drift diameter, after actuation, mm	99	99
Internal overpressure to open collar ports <sup>1</sup> , MPa±10%	30	16,0
Maximum internal overpressure on the collar body, MPa	70	70
Maximum external overpressure on the collar body, MPa	70	70
Maximum tensile axial force on the body <sup>2</sup> , kN	700	700
Maximum operating temperature <sup>3</sup> , °C	100	
Length, mm	903	970
Weight, kg	40	45

<sup>1</sup> Controlling overpressure values are given when all the shear bolts on the unit are used.

<sup>2</sup> Calculated value when stresses reach yield point of the material.

<sup>3</sup> Reference only, depends on operating conditions of general mechanical rubber goods in a well.



# Dissolvable balls

## Main characteristics of dissolvable balls

PARAMETER DESCRIPTION	ЗНАЧЕНИЕ
Density, g/cm <sup>3</sup>	1,55±0,05
Melting Temperature, °C	220
Glass transition temperature, °C	40
Term of ball diameter reduction to the sizes providing free passing through all initiation ports of Bottom Hole Assembly when placed for dissolution, one hour, no longer.	24±2
While frac operation with keeping pressure and holding differential pressure of 70MPA one hour, not less	6
Complete desolation time 1 hour, no longer	100
Coefficient of linear thermal expansion, 1/degree	5,4·10 <sup>-5</sup>
thermal conductivity coefficient, Vt/m*K	0,35

By results of the material supplier carried-out laboratory working off the experimental data of ready-to-go Ø52,4 мм (2") ball solubility were dependent on temperature. These characteristics reflect dependence of speed of dissolution of a Ball on environment temperature are also presented on the chart.

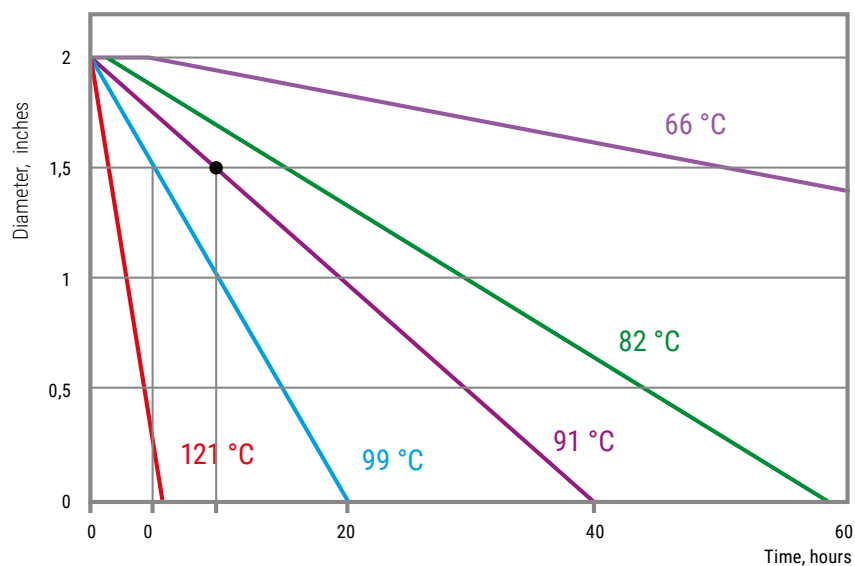

HYDRAULIC FRACTURING





## Bursting frac port

### FPR

Bursting frac port is intended for installation on Liner Assembly with a purpose to be opened by pressure raise to perform frac stages

Installing FPR.114 on liner assembly allows to get a straight-through casing liner to make multi-stage frac with an assembly of selective packers run in on coiltubing.

PARAMETER DESCRIPTION	ЗНАЧЕНИЕ	
	FPR.102	FPR.114
Nominal liner diameter equipped with a device, mm	102	114
Nominal diameter of wellbore (drill bit diameter) to run in the hole, m	123,8	142,9
Outside diameter, mm	118	138
Drift diameter after tool response, mm,	77	99
Inside excess pressure of coupling holes opening, MPa,±10%	60÷65	60÷65
Max excessive internal pressure on the collar body, MPA	70	70
Max external excessive pressure on the collar body, MPa	70	70
Max stretching axial load on the body <sup>1</sup> , kN	700	700
Total area of collar ports opened, cm <sup>2</sup>	11,7	11,7
Max operating temperature <sup>2</sup> , °C	100	
Length, mm	433	430
Weight, kg	16	22

<sup>1</sup> Estimated value of tension to reach a material fluidity limit.

<sup>2</sup> A reference parameter connected with service conditions of rubber elements in the hole.



## Composite Bridge Plug MPR

Drilled out Bridge Plug made of composite material is intended for leak-free isolation of the required intervals zones in the well bore. The plug holds differential pressures up to 700 atm and can be used for multi-staged formation fracs (as per Plug&Perf technology). After frac the plug is easily drilled out. The plug can be run in with any work-string using special multi-usage setting tool. After getting to the planned set depth the setting tool is activated by pumping down the ball to the seat spot in the setting device. Then, with pressuring up setting and detachment of a plug from setting tool is made. The Plugs are issued in several modifications: blind ones, with inner check valve, etc.

PARAMETER DESCRIPTION	VALUE	
	MPR.114	MPR.146
Nominal casing diameter where run in and spot the bridge plug, mm	114	146
Max outside diameter, mm	93	122
Diameter of the flow channel through passage, mm	23	-
Plug activation pressure with installation tool, MPa	16±5%	16±5%
Max differential pressure on the plug, MPa	70	70
Length, mm, not more	600	730
Weight, kg, not more	7,5	17,2



## Collar for collar cementing for hydraulic fracturing **MMC-G**

Collar for Collar Cementing is applied for liner collar cementing with assembly for multistage hydraulic fracturing with isolation of horizontal sector into zones with hydro-mechanical packers.

While using an MMC-G-type collar the following process operations are performed:

- washing and washing ports opening through internal overpressure build-up after isolation of tube space from outer annular space;
- washing with ball-drop;
- cementing ports opening when a ball is set into a collar seat;
- casing cementing with starting of a cementing plug after pumping in cement slurry;
- displacing of cement slurry to the outer casing annular space until receiving the "bump" signal;
- collar ports closing by the internal overpressure build-up.



PARAMETER DESCRIPTION	VALUE	
	MMC-G.102	MMC-G.114
Casing string nominal diameter RIH with the coll	102	114
Open borehole nominal diameter (bit diameter) which the collar is run in, mm	124	142,9
Maximum outer diameter, mm	118	133
Drift diameter, mm	88	98
Values of controlling overpressure for devices actuation <sup>1</sup> , MPa:		
- circulation ports opening;		16,0
- cementing ports opening;		11,0
- cementing ports closing		5,0
Maximum operating temperature <sup>2</sup> , °C		100
Maximum internal overpressure on the collar body <sup>3</sup> , MPa		70,0
Maximum external overpressure on the collar body <sup>3</sup> , MPa		70,0
Maximum tensile force <sup>3</sup> , kN		600 (60)
Length, mm	1715	1121
Weight, kg	58,4	47,9
Connecting threads according to TU 14-161-163-96	OTTM 102	OTTM 114

<sup>1</sup> Controlling overpressure values are given when all the shear bolts on the unit are used.

<sup>2</sup> Reference only, depends on operating conditions of general mechanical rubber goods in a well.

<sup>3</sup> Calculated value when stresses reach yield point of the material.



## Collar control tong KUM.114

The set of equipment includes: a collar control tong and collars GRP geared towards the tong. A collar control tong KUM.114 is a hydraulically actuated device run in on coiled tubing for randomly opening/closing of an unlimited number of GRP collars.

The device has the following main advantages:

1. Tong cams hydraulically actuated with pressure differential.
2. Automatic disconnection of a tong from a collar after its opening/closing.
3. Option of further collar control.
4. Small size of the device.

PARAMETER	VALUE
Outer max Ø, mm	88
Inner Ø, mm	15
Length, mm	449
Activation rate, l/s	4
Activation pressure, MPa	4-5
Connecting threads	Thread 60 GOST 633-80

### Tong operational stages

Collar location

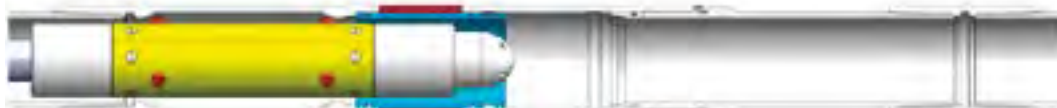

Engagement

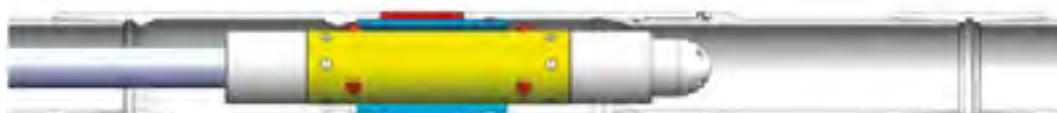

Collar opening



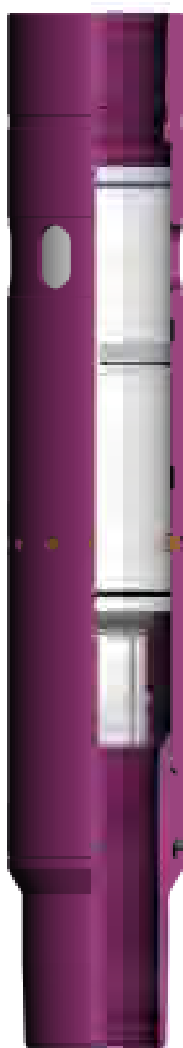

## Collar for staged hydraulic fracturing with an operating device

### MSGRP-U

Collar for Staged Hydraulic Fracturing MSGRP-U is applied for multistage hydraulic fracturing.

A set of collars is RIH as a part of GRP liner assembly. Each collar is installed in the preset wellbore zone. MSGRP collars actuation is performed with the device KUM.114 which is run in on coiled tubing. In this case collars are actuated randomly. Collars actuation is also possible according to the standard process with balls of different diameter. In this case seats are pulled out with a special device and without drilling after collars actuation. Collars are run in as a part of a liner together with swellable and hydro-mechanical packers. Liner assembly includes an unlimited number of collars installation.

PARAMETER DESCRIPTION	VALUE
	MSGRP-U.114
Liner nominal diameter equipped with the device, mm	114
Open borehole nominal diameter (bit diameter) which the device is run in, mm	142,9
Outer diameter, mm	133
Drift diameter, after actuation, mm	99
Maximum internal overpressure on the collar body, MPa	70
Maximum external overpressure on the collar body, MPa	70
Maximum tensile axial force on the body <sup>1</sup> , kN	400
Maximum operating temperature <sup>2</sup> , °C	100
Length, mm	949
Weight, kg	35

<sup>1</sup> Calculated value when stresses reach yield point of the material.

<sup>2</sup> Reference only, depends on operating conditions of general mechanical rubber goods in a well.





Well Casing  
with Noncementing Liner

**136**

Well Casing  
with Noncementing Liner with Washing  
through a Shoe with Zonal Isolation by  
Swellable Packers

**137**

Well Casing  
with Noncementing Liner  
with Zonal Isolation  
by Inflatable Packers

**138**

Well Casing  
with Cementing Liner  
with Continuous Cementing  
with Zonal Isolation by Inflatable Packers

**139**

Well Casing  
with Collar Cementing Liner  
with Additional Isolation of Upper Zones  
by Inflatable Packers

**140**

Well Casing  
with Noncementing Liner  
with Packaging for MSHF  
and Zonal Isolation by Swellable Packers

**141**

Well Casing  
with Collar Cementing Liner  
with Packaging for MSHF  
and Zonal Isolation by Swellable Packers

**142**

Well Casing  
with Collar Cementing Liner  
with Packaging for MSHF  
and Zonal Isolation by Hydraulic Packers

**143**

Well Casing  
with Collar Cementing Liner  
with Two-Stage Cementing

**144**

Well Casing  
with Cementing Liner  
with Continuous Cementing Followed  
by Multistage Hydraulic Fracturing

**145**



## Well casing with noncementing liner

For well casing with noncementing liner the following assembly is used:

1. PHN-type liner;
2. Low-friction and spring centralizers;
3. FS or FB filters (it depends on collector resistance);
4. Check valve (only in case when FS filter is used);
5. Shoe.

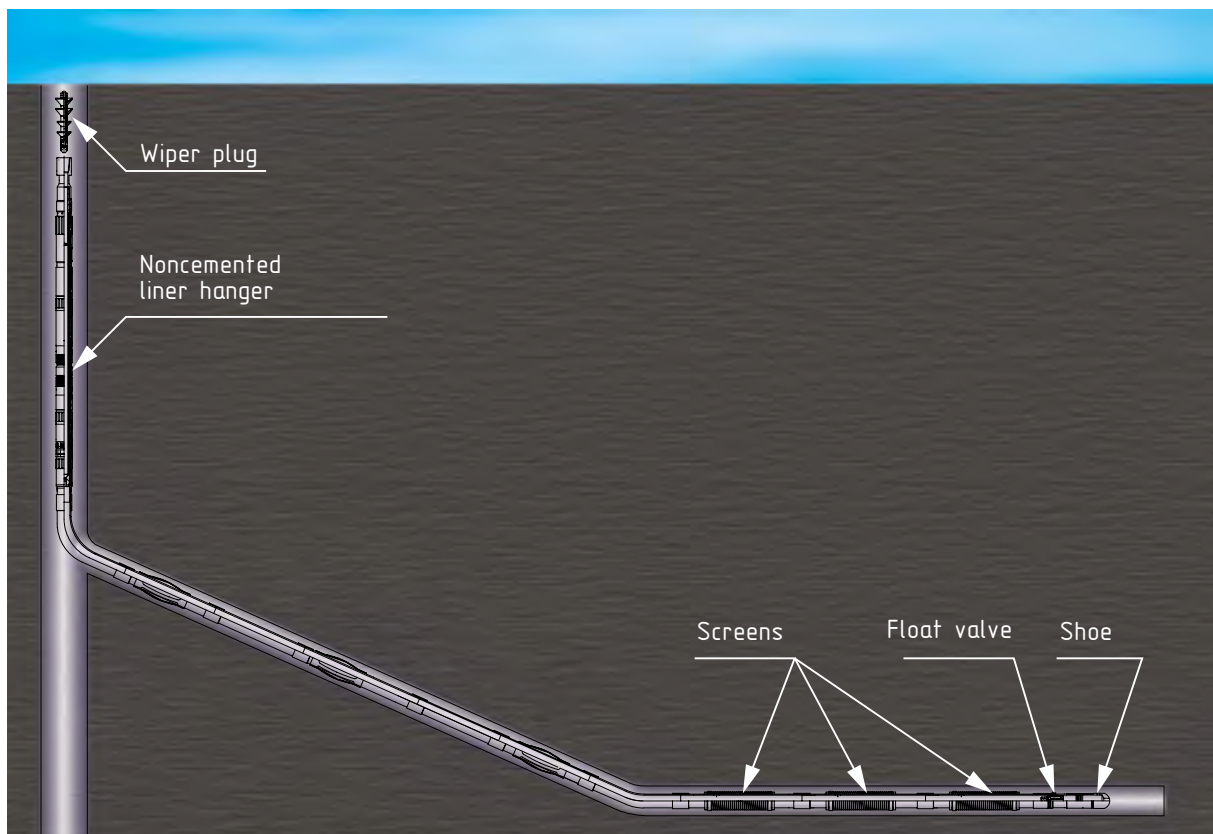

## Well casing with noncementing liner with washing through a shoe with an option of rotating during running in and zonal isolation by swellable packers

For well casing with noncementing liner with washing through a shoe and zonal isolation by swellable packers the following assembly is used:

1. PHN UIF-type hanger or PHNV-UIF (if rotation is needed during running in);
2. Low-friction and spring centralizers;
3. FS or FB filters (it depends on collector resistance);
4. UIF sealing unit;
5. Check valve (only in case when FS filter is used);
6. Shoe.

After liner assembling, the tubing string with a polish rod at the end is RIH till its setting into UIF sealing unit.

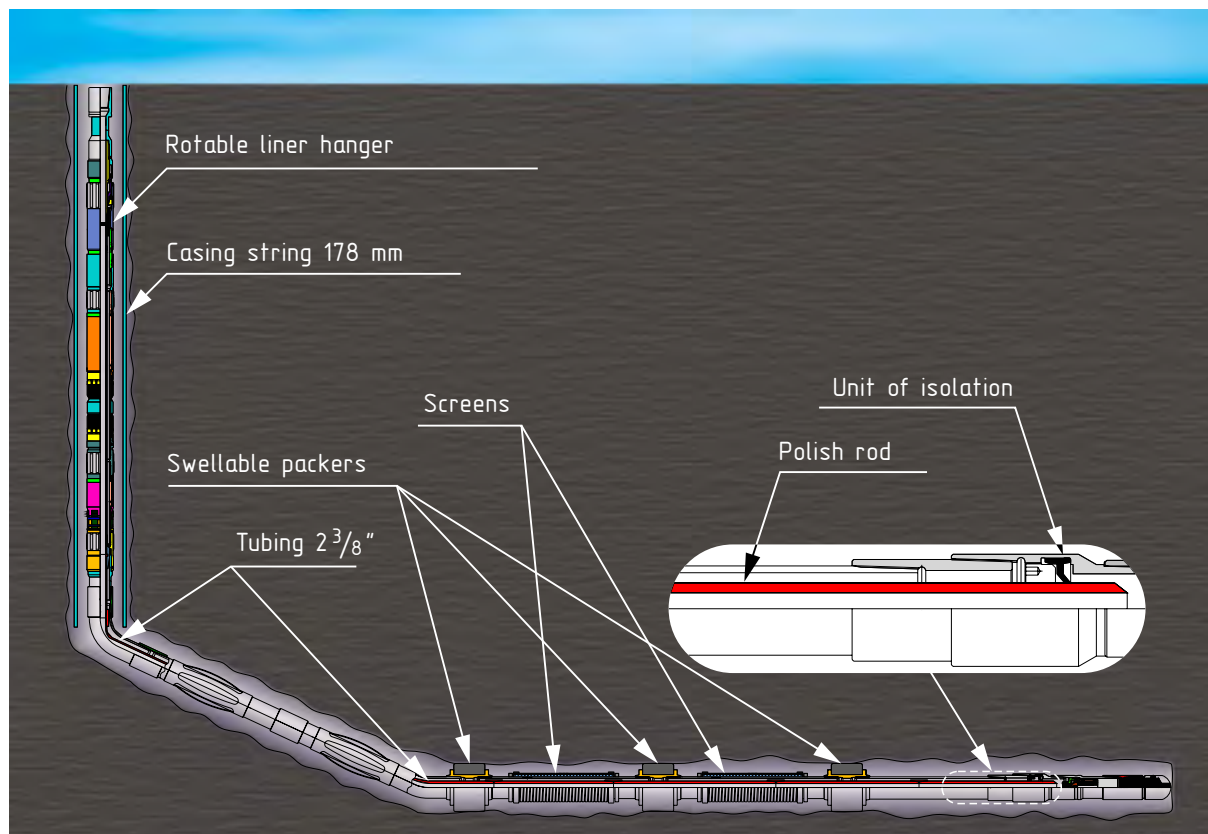

## Well casing with noncementing liner with zonal isolation by inflatable packers

For well casing with noncementing liner with washing through a shoe and zonal isolation by swellable packers the following assembly is used:

1. PHN UIF-type hanger;
2. Low-friction and spring centralizers;
3. PGP packers;
4. UIF2 sealing unit;
5. FS or FB filters (it depends on collector resistance);
6. Check valve (only in case when FS filter is used);
7. Shoe.

After liner assembling, the tubing string with a special rod at the exact part is RIH till its setting into UIF2 sealing unit.

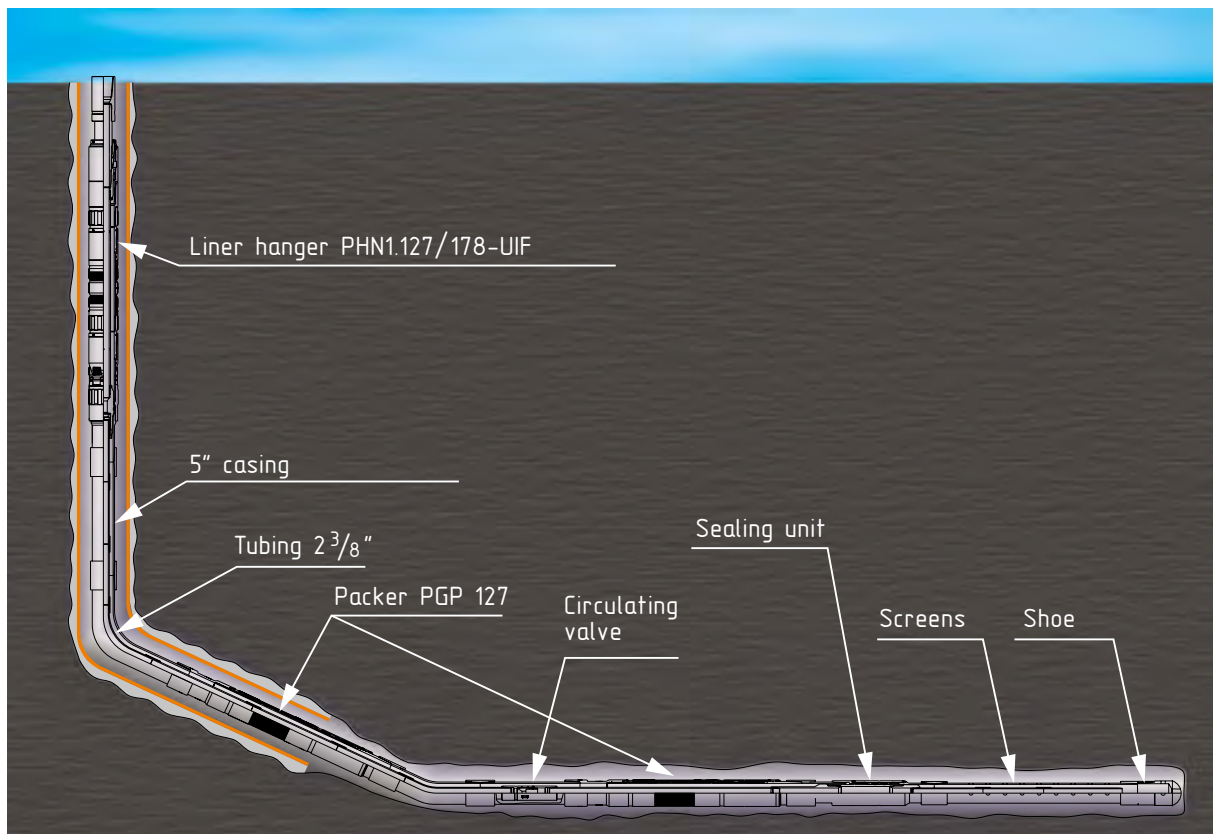

## Well casing with cementing liner with continuous cementing with zonal isolation by inflatable packers

For well casing with cementing liner with continuous cementing with zonal isolation by inflatable packers the following assembly is used:

1. PHCZ or PHGMC or PHRC hanger;
2. Cementing basket CK;
3. Low-friction and spring centralizers;
4. PGP packer;
5. Stop-tap;
6. Valve KOSH2;
7. Shoe.

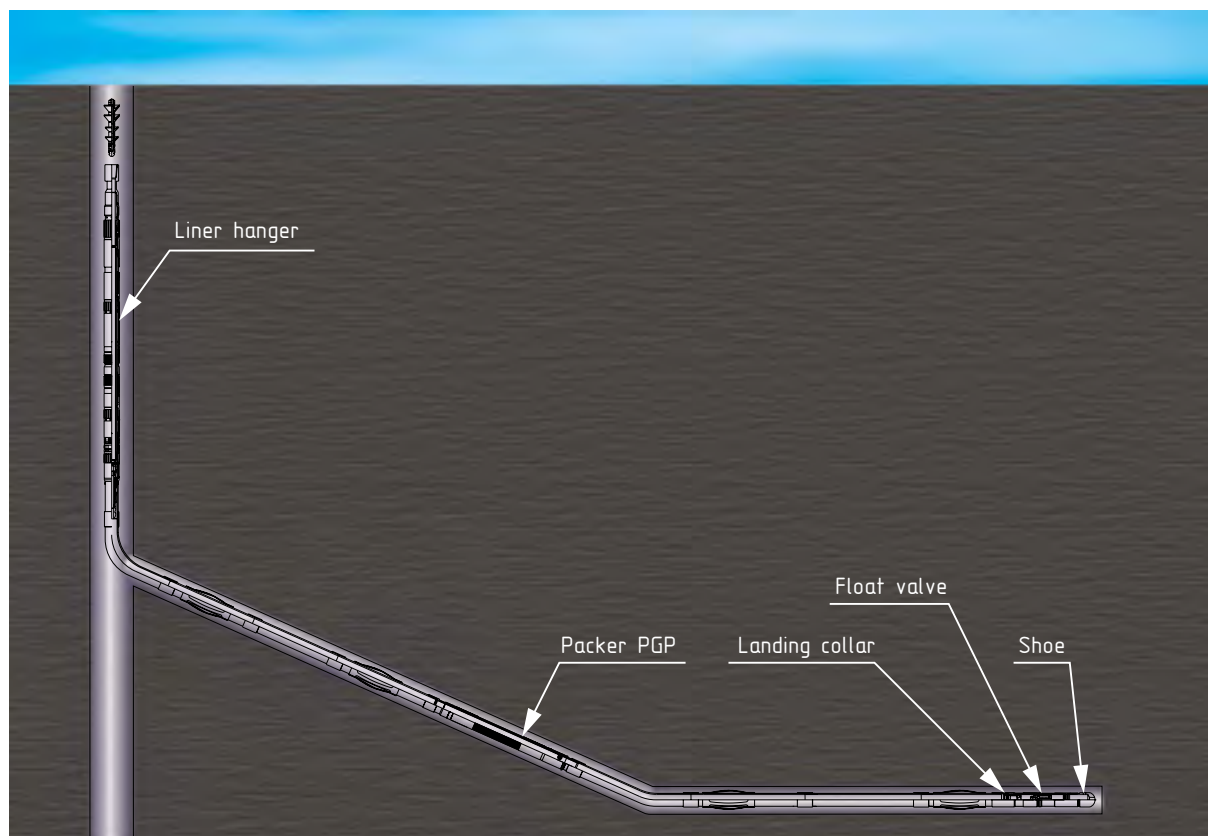

## Well casing with collar cementing liner with additional isolation of upper zones by inflatable packers

For well casing with collar cementing liner with additional isolation of upper zones by inflatable packers the following assembly is used:

1. PHCZ or PHGMC or PHRC hanger;
2. PGP packer (one or several);
3. Cementing basket CK;
4. Low-friction and spring centralizers;
5. PGMC packer;
6. FS or FB filters (it depends on collector resistance);
7. Valve KOSH2;
8. Shoe BK-M.

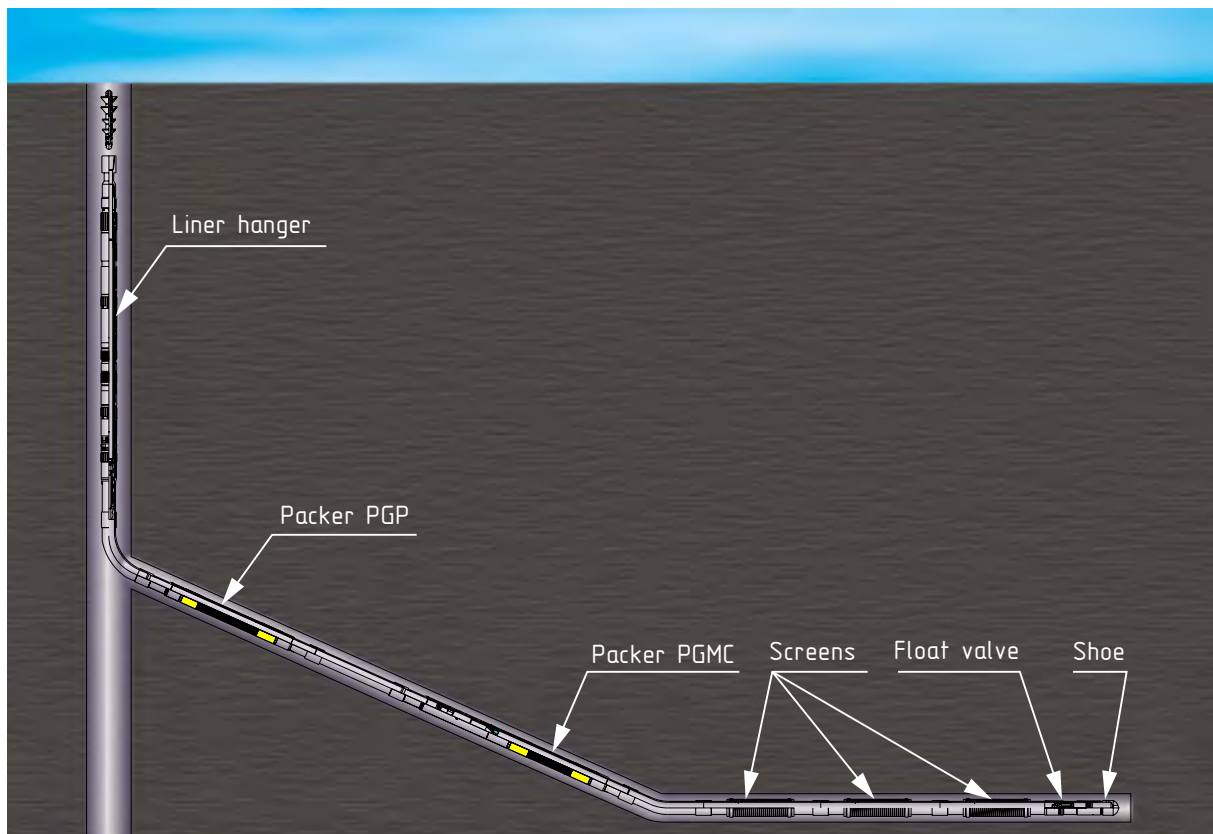

## Well casing with noncementing liner with packaging for MSHF and zonal isolation by swellable packers

For well casing with noncementing liner with packaging for MSHF and zonal isolation by swellable packers the following equipment is used:

1. PHN-type hanger;
2. Low-friction and spring centralizers;
3. PGRP packers;
4. Collars MSGRP or FPZ (for balls);
5. Collars MSGRP-G or FPZ-G (opening hydraulically);
6. Valve KO;
7. Check valve;
8. Shoe.

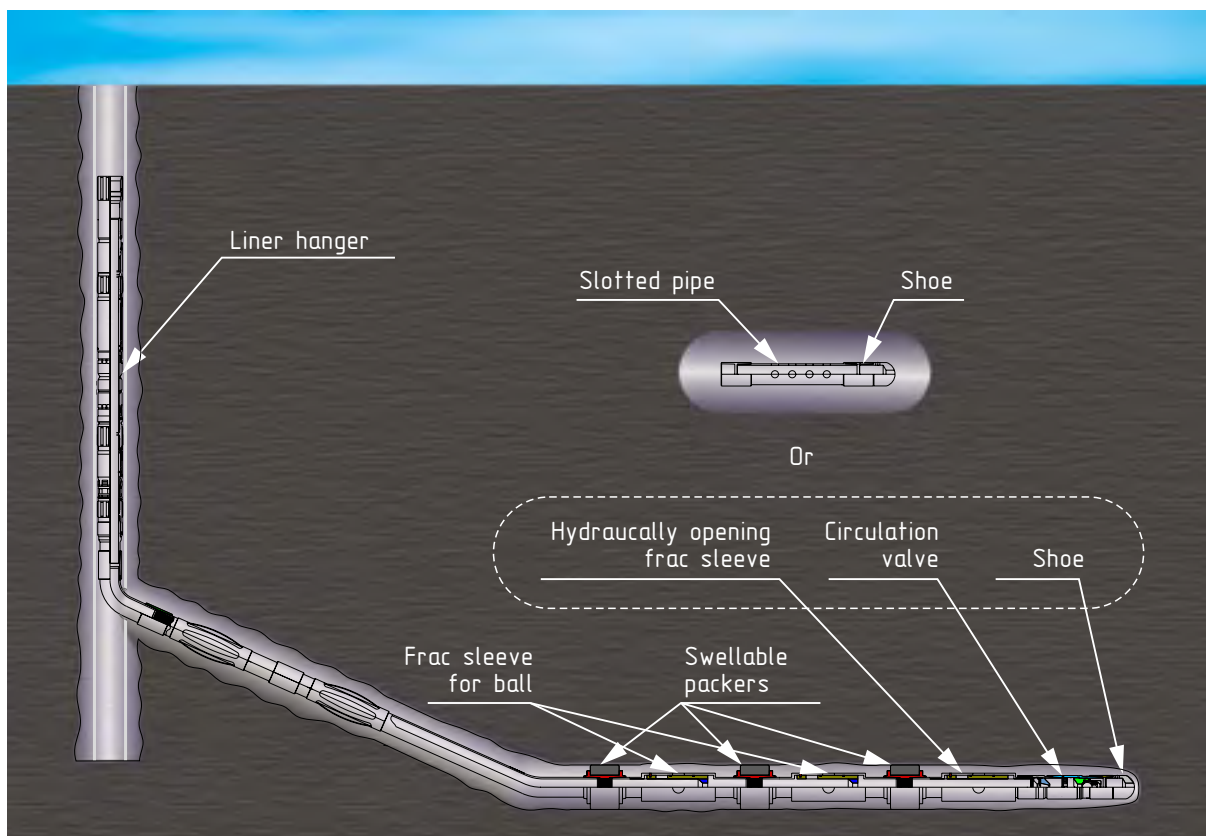

## Well casing with collar cementing liner with packaging for **MSHF** and zonal isolation by swellable packers

For well casing with collar cementing liner with packaging for MSHF and zonal isolation by swellable packers the following equipment is used:

1. PHCZ or PHGMC hanger;
2. Cementing basket CK;
3. Low-friction and spring centralizers;
4. PGMC packer;
5. Seat-trap;
6. PNN or PNV packers;
7. Collars MSGRP for balls;
8. Perforated joint;
9. Shoe BK-M.

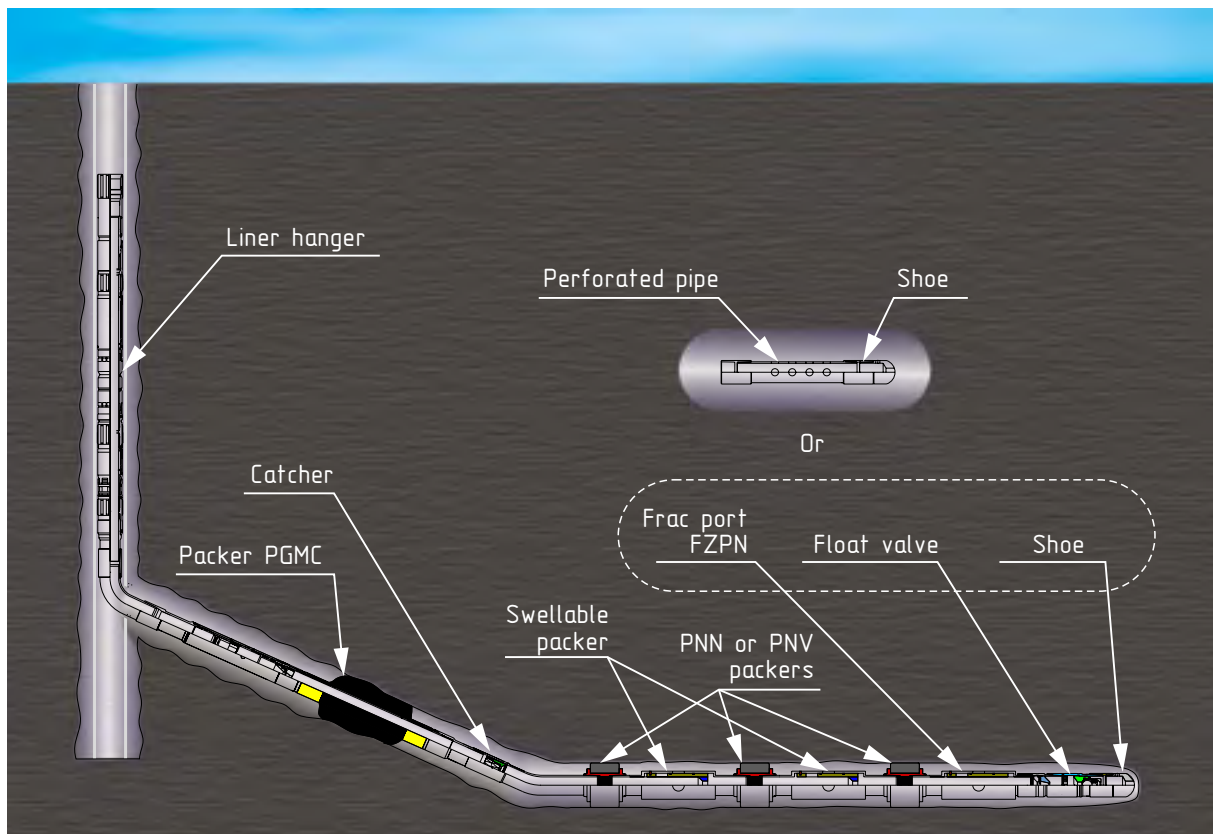



## Well casing with collar cementing liner with packaging for **MSHF** and zonal isolation by hydraulic packers

For well casing with collar cementing liner with packaging for MSHF and zonal isolation by hydro-mechanical packers the following equipment is used:

1. PHCZ or PHGMC hanger;
2. Cementing basket CK;
3. Low-friction and spring centralizers;
4. MMCG collar;
5. Seat-trap SL;
6. PGRP packers;
7. Collars MSGRP (for balls);
8. Collar MSGRP-G (opening hydraulically);
9. Valve KO;
10. Valve KOSH2;
11. Shoe BK-M.

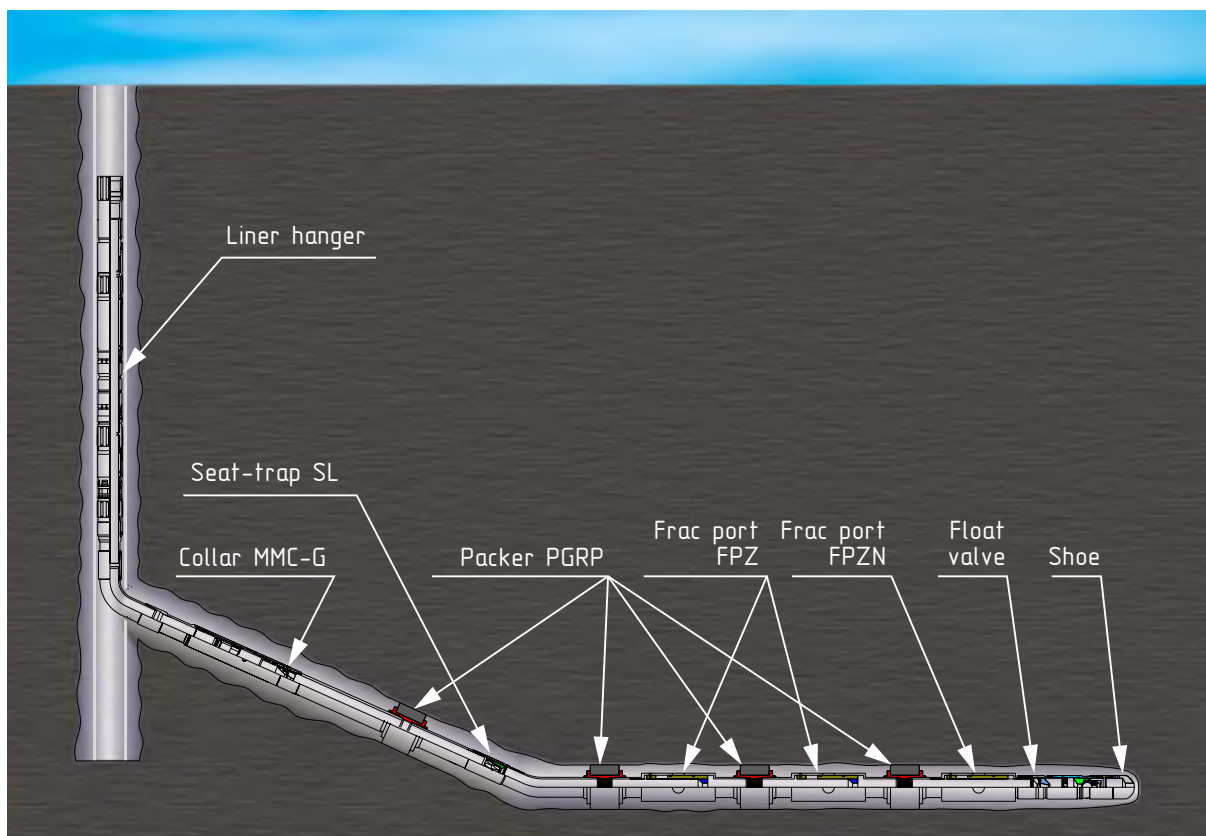

## Well casing with collar cementing liner with two-stage cementing

1. For well casing with collar cementing liner with two-stage cementing the following equipment is used:
2. PHZSC hanger;
3. Low-friction and spring centralizers;
4. Collar MMC1;
5. PGMC packer;
6. FS or FB filters (it depends on collector resistance);
7. Check valve (only in case when FS filter is used);
8. Shoe BK-M.

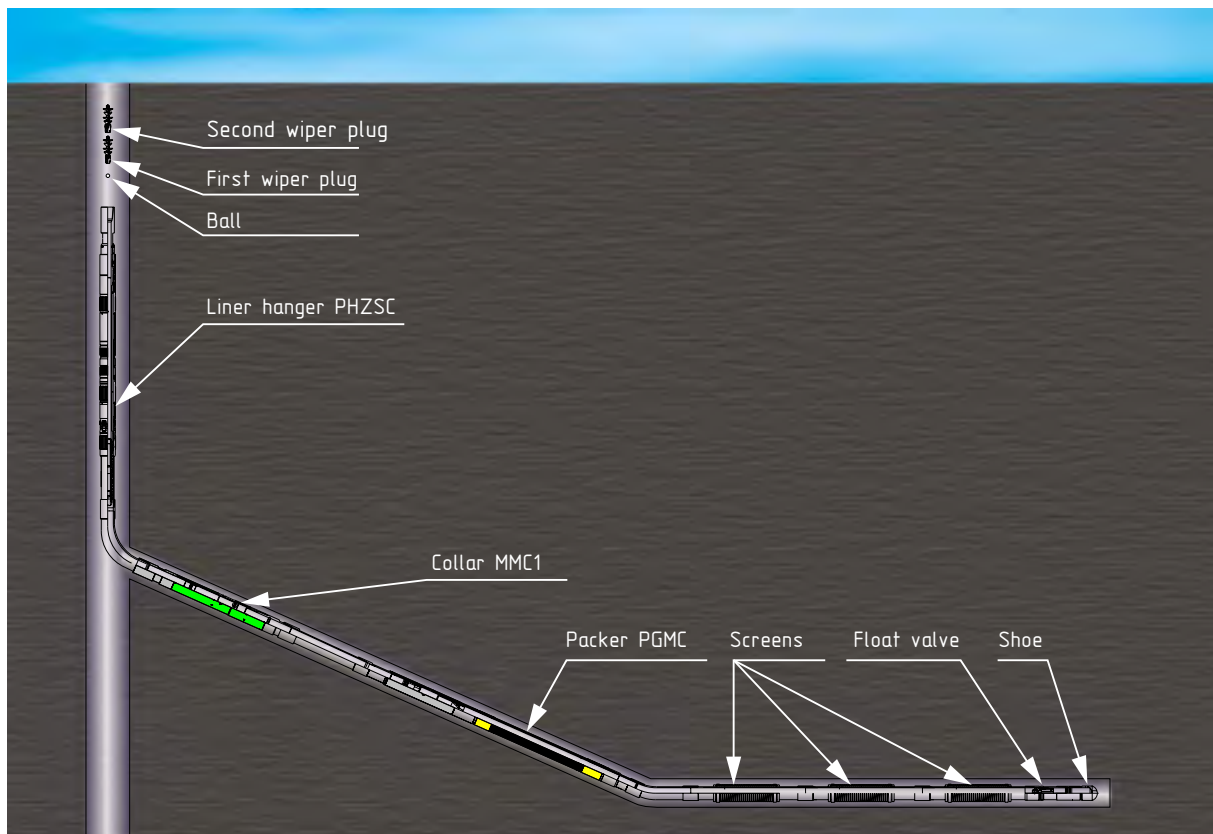

## Well casing with cementing liner with continuous cementing followed by multistage hydraulic fracturing

For well casing with cementing liner with continuous cementing with packaging for MSHF the following assembly is used:

1. PHGMC or PHRC hanger;
2. Spring centralizers;
3. MSGRP-C collar;
4. MSGRP-G (C) collar;
5. Stop-tap;
6. Check valve;
7. Shoe BK-M.

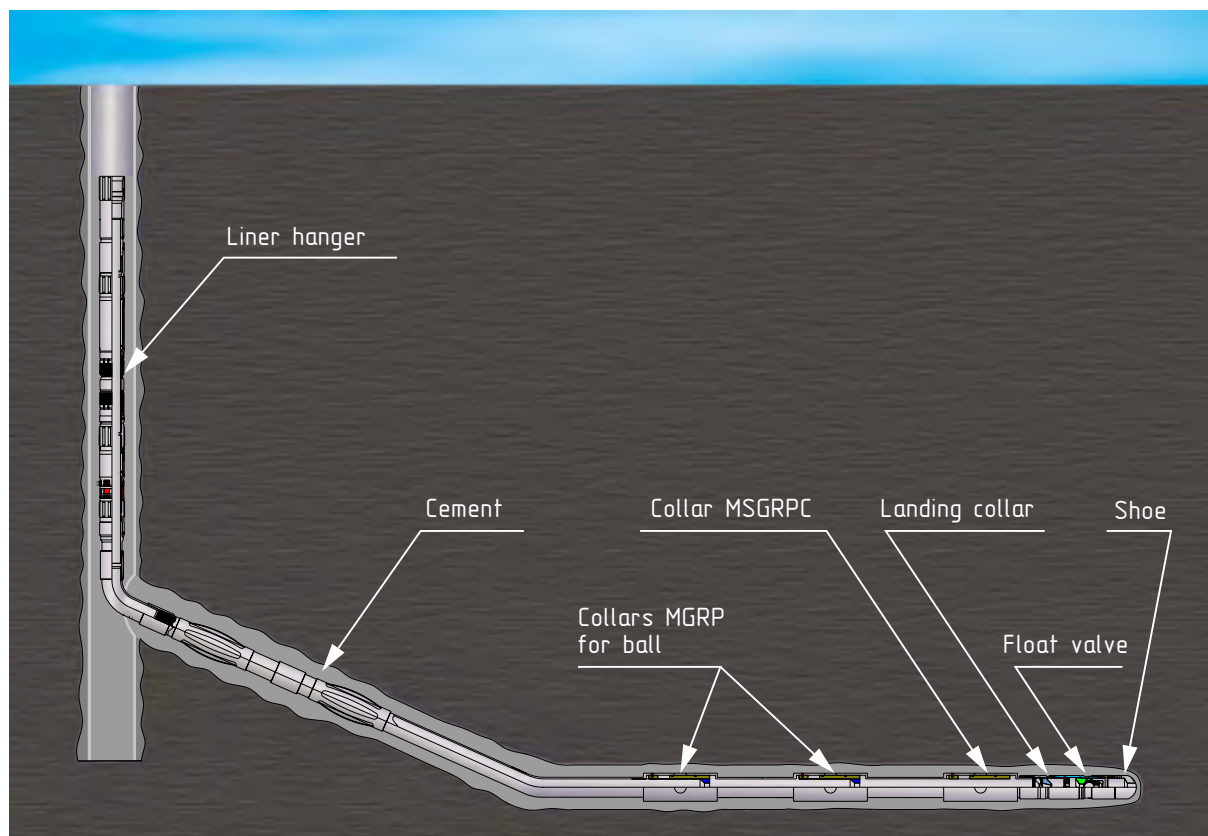



[www.zers.ru](http://www.zers.ru)

LLC "NTC "ZERS"

+7 (495) 632-21-94/95/96 | [WWW.ZERS.RU](http://WWW.ZERS.RU) | [INFO@ZERS.RU](mailto:INFO@ZERS.RU)

**Moscow:** 107078, Moscow, Novaya Basmannaya str., 14-1  
Phone: +7 (495) 632-21-94/95/96/97

**Ryazan:** 390025, Ryazan Region, Ryazan, Promyshlennaya str., 21  
Phone/fax: +7 (4912) 500-337, 500-338, 500-339, 500-340  
+7 (495) 632-21-94/95/96/97, ext. 146

**Nizhneartovsk:** 628600, Tyumen Region, KMAD-Yugra, Nizhneartovsk, Industrialnaya str., 29  
Phone/fax: +7 (922) 655-32-46, +7 (495) 632-21-94/95/96/97, ext. 154

**Noyabrsk:** 629803, Tyumen Region, YNAD, Noyabrsk, industrial zone, pan. 4  
Phone/fax: +7 (912) 071-28-80, +7 (495) 632-21-94/95/96/97, ext. 153

**Irkutsk:** 664047, Irkutsk Region, Irkutsk, Sovetskaya str., 124-E  
Phone: +7 (904) 151-54-60, +7 (495) 632-21-94/95/96/97, ext. 170

**Buzuluk:** 461042, Orenburg Region, Buzuluk, Pyatigorskaya str., 39a build  
Phone: +7 (922) 537-42-38, +7 (495) 632-21-94/95/96/97, ext. 155

